



# NEEDS TAILORED **INTEROPERABLE** RAILWAY INFRASTRUCTURE

# NeTIRail

Needs Tailored Interoperable Railway Infrastructure

## Deliverable 2.2

### Practices and track technology tailored to particular lines

Submission date : 30/11/2015



NeTIRail-INFRA is funded by the European  
Commission under the Horizon 2020  
programme - Grant agreement n° 636237



## **Lead contractor**

---

ADS-ELECTRONIC RESEARCH

## **Contributors**

---

USFD, SZ, AFER, INTADER, UIC, RCCF

## **Project Coordinator**

---

University of Sheffield, USFD

## Executive Summary

---

In recent years, the amount of traffic that the railways have to carry has increased and this is expected to continue into the future, combined with higher speeds has meant that the duty conditions of rail have become more severe.

In this report are presented the main components and activities of a railroad network. Described are the achievement and installation possibilities which have the highest efficiency and reliability.

Among the variants of existing technologies and solutions in different geographic areas, comparisons are made and those that proved the best results are highlighted.

They address issues regarding the components and technologies used in the three main stages in the life of the railway line: installation, operation and maintenance.

For existing lines, the focus will be on the operational activities and maintenance, while for completely new installations or significant rebuilding are described multiple technologies and technical solutions as, their implementation in these conditions, are possible and necessary.

Information and results from previous projects conducted in this area of application, including the InnoTrack and Mainline Project, will be used.

The three categories of railway lines (busy passenger line, low density rural / secondary line, dominated freight route), need to be analysed in the project, and were identified as real lines. These lines belong to the infrastructure managers involved in the project and will complete a list of case studies.

T2.2 has benefited from the analysis result of T1.1. This task was completed in the fourth month of the project and defined, after a strict selection, a list with seven lines that may be included in the three categories as defined for the purpose of analysis and improvement in the NeTIRail Project. All these lines contain common characteristics that made them candidates for selection.

For Slovenia, SZ selected railway lines were: Divača - Koper (as freight dominated route); Pivka - Ilirska Bistrica (as low density rural / secondary line); Ljubljana - Kamnik (busy passenger line). For Romania, from RCCF-Brasov, was selected the railway line Bartholomew - Zarnesti (as low density rural/ secondary line). For Turkey, INTADER selected the railway lines: Kayaş - Sincan (as busy passenger line) Divriği - Malatya (as low density rural / secondary line) Malatya - İskenderun (as freight dominated route).

Existing components and practices used in the operational and maintenance activities for the case studies, covering all the three categories of lines, have been analysed and solutions to improve the current situation have been proposed.

## Table of contents

---

Executive Summary .....	3
Table of contents .....	4
Abbreviations and acronyms .....	9
1 Railway transport infrastructure .....	10
1.1 General aspects of railway transport infrastructure .....	10
1.2 Subgrade and formation .....	10
1.2.1 Investigation of site .....	11
1.2.2 Subgrade material .....	11
1.2.3 General description of formation .....	11
1.2.4 Slopes of formation .....	12
1.2.5 Execution of earthwork .....	12
1.2.6 Blanket material procedure .....	13
1.2.7 Railway embankment failure .....	13
1.2.8 Corrective measures .....	14
1.2.9 Soil stabilization by geotextiles .....	15
1.3 Ballast .....	15
1.3.1 Ballast types .....	16
1.3.2 Sub-ballast provision .....	17
1.3.3 Self-stabilizing track .....	17
1.4 Sleepers (Ties) .....	18
1.4.1 Wooden Sleepers .....	18
1.4.2 Cast Iron Sleepers (CI) .....	20
1.4.3 Concrete Sleepers .....	20
1.5 Rail .....	22
1.5.1 Types of rails .....	22
1.5.2 Adopting of flat-footed rail .....	23
1.6 Rail degradation and failure mechanisms .....	24
1.6.1 “Minimum action” Rule .....	28
1.6.2 Corrugation of rails .....	29
1.6.3 Rail degradation mechanisms .....	30
1.6.4 Loss of rail profile .....	31

1.6.5	Rolling Contact Fatigue (RCF) .....	31
1.6.6	Rail breakage .....	33
1.6.7	External studies confirm InnoTrack results .....	34
1.6.8	Rail failure .....	35
1.7	Rail Grinding.....	35
1.7.1	Initial grinding .....	36
1.7.2	Corrective grinding.....	36
1.7.3	Preventive Grinding.....	37
1.7.4	Conclusions for grinding procedure .....	39
1.7.5	Potential improvement through preventive actions.....	40
1.8	Linking rails – rail joints and rail welding .....	41
1.8.1	Rail Joints Necessity .....	41
1.8.2	Rail Joint classification .....	42
1.8.3	Rail joint welding.....	43
1.8.3.1	Flash Butt Welding .....	45
1.8.3.2	Gas Pressure Welding.....	48
1.8.3.3	Thermite Welding of Rails .....	48
1.8.3.4	Modern Technologies used in welding rails.....	52
1.9	Long-welded rail (LWR) .....	54
1.9.1	Longitudinal Thermal Expansion of LWR and Breathing Length .....	54
1.9.2	Prohibited Locations of LWR .....	55
1.9.3	Switch Expansion Joint.....	55
1.9.4	De-stressing of LWR .....	56
1.9.5	Continuous Welded Rails .....	57
1.9.6	Buckling of Track .....	57
1.10	Gauge .....	57
1.11	Switch and Crossings.....	59
1.11.1	Switches .....	60
1.11.2	Crossings .....	63
2.	Technologies for completely new installations, or significant rebuilding railway lines .....	66
2.1	General considerations .....	66
2.1.1	Standard elements should be considered for new construction: .....	66
2.1.2	Modern techniques for surveying activities.....	67

2.2	Alignment Selection .....	68
2.2.1	Optimising route alignment .....	68
2.2.2	Mountain alignment .....	70
2.3	Choice of gauge for new lines and conversion of existing gauges .....	71
2.3.1	Problems caused by multi - gauge system .....	72
2.3.2	Advantages of a one gauge system .....	72
2.4	Rail Grade Selection .....	73
2.4.1	Guidelines for rail grade selection .....	74
2.4.2	New developed criteria for Rail Grade Selection .....	75
2.4.2.1	Local Parameters .....	76
2.4.2.2	Rail maintenance methods .....	77
2.4.2.3	Economic Issues .....	77
2.4.3	Recommendations for Rail Grade Selection .....	77
2.4.4	Conclusions .....	78
2.5	Main influencing variables on costs of logistic chain for new lines rail supply .....	79
2.5.1	Rail length .....	79
2.5.2	Rail welding .....	79
2.5.3	Transportation .....	80
2.5.4	Stock keeping .....	80
2.5.5	Manipulation .....	80
2.6	Crossing types for new installations or rebuilding railway lines .....	80
2.6.1	Cost drivers analysis .....	80
2.6.1.1	Constraints for data analysis that should be considered: .....	80
2.6.1.2	Cost drivers for high speed line from DB (Deutsche Bahn) Railway .....	81
2.6.1.3	Cost drivers for high speed line from Banverket Railway .....	81
2.6.2	General Considerations for Switch and Crossings Optimisation .....	82
2.6.3	Optimization Categories for S & C .....	82
2.6.3.1	Optimization of geometry and stiffness in the switch panel .....	83
2.6.3.2	Optimization of dynamic track gauge in the switch panel .....	86
2.6.3.3	Optimization geometry and support stiffness in crossing panel .....	87
2.7	Technologies for replacement of Switches and Crossings (18) .....	88
2.7.1	Classification of S&C replacement methods .....	90
2.7.2	Phases of S&C replacement methods .....	90
2.7.3	German practice (DB) .....	91

2.7.4	Spanish practice (COMSA).....	93
2.7.5	Swedish practice (Banverket/Trafikverket) .....	95
2.7.6	Czech practice (Skanska) .....	95
2.7.7	Hungarian practice (MAV).....	97
2.7.8	Turkish practice (TCDD).....	97
2.7.9	British practice (Network Rail) .....	98
2.8	Sleeper spacing and sleeper solution .....	99
2.8.1	Sleeper density and spacing of sleepers .....	100
2.8.2	Concrete sleepers solution.....	100
2.8.3	Concrete sleepers advantages: .....	101
2.8.4	Concrete sleepers disadvantages:.....	101
2.8.5	Design considerations of concrete sleepers.....	101
2.8.6	Concrete sleepers for heavier axle load .....	102
2.9	Ballast and sub-structure. ....	103
2.10	Railways Modernization - Trends and Strategies .....	107
2.10.1	General considerations .....	107
2.10.2	Track and infrastructure modernization for high speed trains. ....	108
2.10.2.1	Strategies for introducing high-speed trains:.....	108
2.10.2.2	High Speed Railways in the world .....	108
2.10.2.3	Infrastructure Track Structure for High-Speed Routes .....	109
2.10.2.4	Tilting Trains for High-Speed Routes .....	110
2.10.3	Dedicated Freight Railway Corridor .....	111
2.10.3.1	Advantages of Dedicated Freight Corridor (DFC) .....	111
2.10.3.2	Improvements recommendations for designing DFC .....	112
3.	Technologies and practice used in partners' countries .....	113
3.1	General observations .....	113
3.2	Technologies and practice used in United Kingdom .....	113
3.2.1	Categories of track lines .....	113
3.2.2	Switches and crossings.....	114
3.2.3	Choice of rail joints.....	115
3.2.4	Choice of rail types.....	118
3.2.5	Choice of lubrication .....	120
3.2.6	Choice of inspection frequency .....	120
3.2.7	S&C lubrication .....	121

3.3	Technologies and practice used in the Netherlands .....	122
3.4	Technologies and practice used in Slovenia .....	122
3.5	Technologies and practice used in Romania .....	123
3.5.1	General presentation .....	123
3.5.2	The rail.....	124
3.5.3	Sleepers.....	124
3.5.4	Fastening systems .....	125
3.5.5	Crushed stone .....	125
3.5.6	Points and crossings.....	125
3.5.7	Railway stations and marshalling yards .....	125
3.5.8	Level crossings.....	126
3.6	Comparative table for the seven case studies chosen in the NeTIRail Project .....	127
3.7	Slovenia – case studies.....	133
3.7.1	Rail line Divača - Koper:.....	133
3.7.2	Rail line Pivka - Ilirska Bistrica .....	135
3.7.3	Rail line Ljubljana - Kamnik .....	136
3.8	Romania – case study.....	137
3.8.1	Rail line Bartolomeu - Zarnesti.....	137
3.9	Turkey – case studies.....	139
3.9.1	Kayaş - Sincan .....	139
3.9.2	Divriği - Malatya .....	140
3.9.3	Malatya - İskenderun .....	141
4.	Conclusions .....	144
5.	References .....	148



## Abbreviations and acronyms

Abbreviation / Acronym	Description
ABC	Activity Based Costing
AT	Aluminothermic Weld
BV	Banverket – former Swedish IM
CM	Corrective Maintenance
CWR	Continuous Welded Rail
DB	Deutsche Bahn – German IM
EC	Eddy Current
EU	European Union
FB	Flash Butt Weld
FME(C)A	Failure Mode, Effects (and Criticality) Analysis
FMEA	Failure Modes and Effects Analysis
HA	Hazard Analysis
HAZ	Heat Affected Zone
ICT	Information and Communications Technology
IM	Infrastructure Manager
IM's	Infrastructure Managers
JBV	Jernbaneverket – Norwegian IM
LCA	Life-Cycle Assessment
LCC	Life-Cycle Costing / Life-Cycle Cost
LWR	Long Welded Rail
M&R	Maintenance and Renewal
MAD	Mean Administrative Delay
MGT	Traffic in million gross tonnes
MGT/MGTPA	A measure of traffic in units of million gross tonnes per annum
MLD	Mean Logistic Delay
MRT	Mean Repair Time
MTTF	Mean Time To Failure
NR	Network Rail – British IM
ÖBB	Österreichische Bundesbahnen – Austrian IM
PM	Preventive Maintenance
RAM	Reliability, Availability and Maintainability
RAMS	Reliability, Availability, Maintainability and Safety
RCF	Rolling Contact Fatigue (in this case usually related to head checks)
S&C	Switches & crossings
SA	Safety Analysis
TCDD	Türkiye Cumhuriyeti Devlet Demiryolları – Turkish IM
TGV	Train à Grande Vitesse (High Speed Train)
TSL	Temporary Speed Limitation
UIC	Union Internationale des Chemins (International Union of Railways)
US/UT	Ultra-Sonic / Ultra Sonic Testing

## 1 Railway transport infrastructure

### 1.1 General aspects of railway transport infrastructure

Track is the way upon which the railway runs and its alignment have to be set to within a millimetre of the design, from safety transport reasons. Track design and construction is a component of a complex and multi-disciplinary engineering science involving earthworks, steelwork, and timber and suspension systems and represents an essential part of the infrastructure of the railway.

Many different systems exist throughout the world and there are many variations in their performance and maintenance. Some basic elements of railway transport infrastructure and track design and construction are presented below.

The track is a fundamental part of the railway infrastructure and being the steering base for the train. The modern railway is based on the steel wheel running on a steel rail. Other forms of guided vehicle technology are rubber-tired trains, magnetic levitation, etc.

The main parts of an electrified, double-track line of the railway transport infrastructure are presented in the figure below.

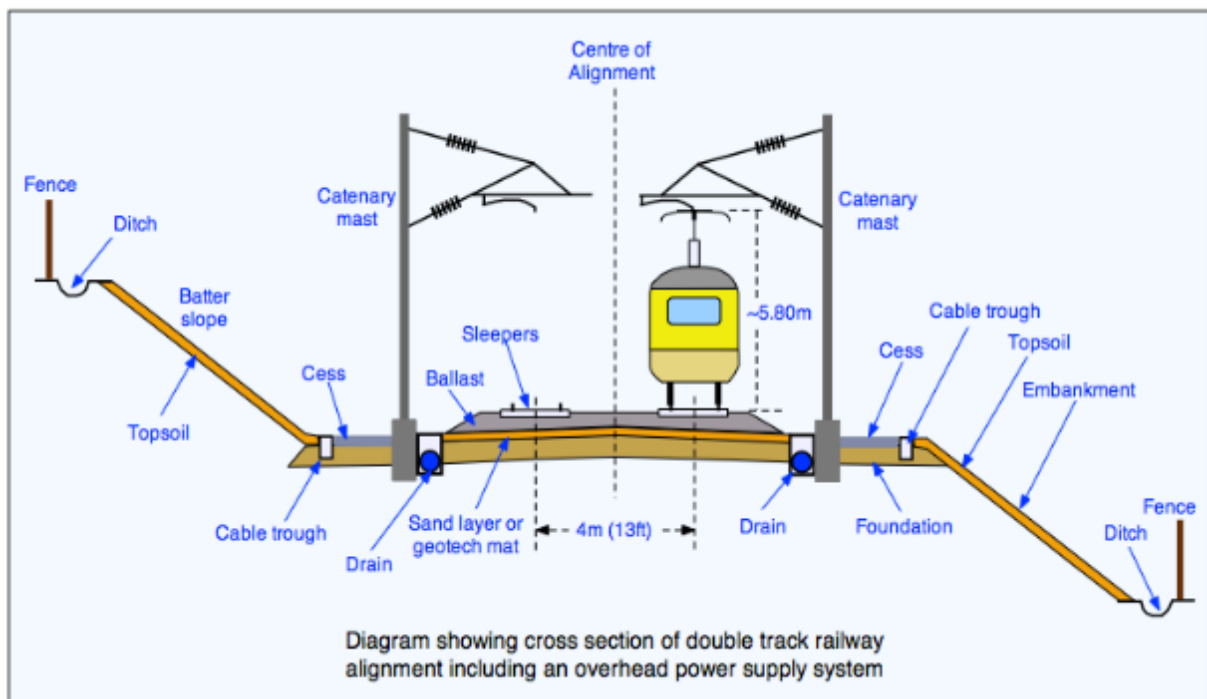

Figure 1.1 Railway transport infrastructure - the principal parts of an electrified, double-track line<sup>1</sup>

### 1.2 Subgrade and formation

Subgrade or formation is the natural soil which is prepared and compacted at its maximum density to receive the ballast and the track. Formation is represented by the prepared flat surface, which is

<sup>1</sup> <http://www.railway-technical.com/track.shtml>

ready to receive the ballast. The formation is an important constituent of the track, as it supports the entire track structure. The track should be designed in such a way that the stresses transmitted to the formation do not exceed the allowed limits. The bearing capacity of the soil depends upon the type of soil and the degree of compactness. The formation may fail in different modes, and remedial measures should be taken in time to safeguard the track.

### **1.2.1 Investigation of site**

The particular data should be collected and the dedicated activities should be achieved to determine the type of work and treatment for formation. Data should be collected regarding the history of the affected section; this task includes information about the time of construction, methodologies for construction, date of opening to traffic, sub-soil, bank settlement slips, and speed restrictions. Indicators should be collected such as volume and costs of maintenance activities for last years. These are necessary to get an idea of track maintainability. Various details should be collected such as bank heights, depth of cuttings, nature of existing slopes, drainage conditions, stagnation of water, condition and proximity of borrow pits, underground water level and past situations during rains that can jeopardize the railway integrity.

### **1.2.2 Subgrade material**

The requirements of subgrade material:

- Have to drain water entering from top.
- Need to be able to bear the load transferred to it by the ballast section.
- Should prevent the ballast from perforating.
- Not be permitted to change its volume due to variation in moisture.

Subgrade material is generally obtained from the borrow pits in the adjacent land. The selection of soils for subgrade is, therefore, quite difficult unless either the alignment is changed or the subgrade material is imported from an outside place.

### **1.2.3 General description of formation**

As a component of railway track, the formation has to provide the following functions:

- Stability to the track.
- Smooth and uniform bed for laying the track.
- Bearing the load transmitted to it from the moving loaded trains, through the ballast.
- Possibility for drainage.

The formation can be in the shape of an embankment or a cutting. The embankment type formation is in the shape of a raised bank and is constructed above the natural ground. If the formation is at level below the natural ground is called a cutting. Generally, a cutting or an excavation is made through a hilly or natural ground for providing the railway line at the required level, below the ground level.



**Figure 1.2 - Cutting formation of Lötschberg - Bahn, Switzerland <sup>2</sup>**

The formation is prepared either by providing additional earthwork over the existing ground to make an embankment or by excavating the existing ground surface to make a cutting. The height of the formation depends upon the ground contours and the gradients adopted. The side slope of the embankment depends upon the shearing strength of the soil and its angle of repose. The width of the formation depends upon the number of tracks to be laid, the gauge, and other factors.

#### **1.2.4 Slopes of formation**

The side slopes are protected to prevent erosion of the side slopes due to rain water, etc. For this purpose, a layer of cohesion soil is used. Alternatively, the slopes are protected with a suitable type of grass.

The side slopes of both the embankment and the cutting depend upon the shearing strength of the soil and its angle of repose. The stability of the slope is generally determined by the slip circle method. In actual practice, average soil such as sand or clay may require a slope of 2: 1 (horizontal: vertical) for an embankment and 1: 1 or 0.5: 1 or even steeper particularly when rock is available for cutting.

#### **1.2.5 Execution of earthwork**

Experience has shown that many of the problems in the maintenance of the track are due to incorrect methods of execution of earthwork. The stability of the formation depends, in general cases, upon the sub grade material and the methods of construction.

The layers should be compacted preferably at or near the optimum moisture content with suitable rollers so as to achieve the needed dry density. First operation of this aspect is mechanical compaction of the earthwork; this activity should be done in layers having proper and stated thickness using, for example, vibratory rollers. Proper quality control should be exercised during mechanical compaction.

The soil that is used for execution of earthwork should be framed in his category in the beginning of surveys activities. This will be done through taking soil samples from the site. The soil is classified as “good” or “other-than-good” depending upon its grain size and consistency limits. Generally, coarse-

---

<sup>2</sup> <https://bahnbilder.ch/picture/6302>; Author: David Guble

grained soils will be framed in the category of good soils. Fine-grained soils (inorganic clay, silts, sandy soils, clayey soils, etc.) are grouped into category of other-than-good soils.

Track drainage is considered as a property of the track to dispose of the water from upon or under the track. It is accomplished by a surface and sub-surface drainage system. This function of drainage of the subgrade is very vital, as excess water reduces the bearing capacity of the soil's resistance to shear.

### 1.2.6 Blanket material procedure

The blanket is defined as an intervening layer material that is provided in the body of the bank under ballast layer. It is different from the sub-ballast, which is provided above the formation. The function of the blanket are:

- Reducing the rainwater infiltration into the formation soil.
- Minimising the perforation of the stone ballast into the formation soil.

Generally, the blanket will cover the entire width of the formation from the shoulder, except in the case of sand or similar erodible material. The depth of the blanket will be normally about 30 cm in ordinary clayey soil. In the case where the formation soil is particularly weak, a thicker layer of up to 60 cm may be necessary, depending on the shear properties of the formation soil.

#### **Blanket material properties for sand, quarry grit, gravel, and other non-cohesive materials:**

- The blanket material should be coarse and granular.
- The material should be properly graded and its particle size distribution curve should lie within the standard enveloping curves.
- If an erodible material is used as a blanket, it should be confined in a trench and sand drains should be provided across the track and the blanket.

The depth of blanket layer of a specified material depends mainly by the type of sub grade soil and the axle load of the traffic. In case there is of more than one type of soil in the top of formation, then the soil requiring higher thickness of blanket will lead the solution.

**Soil not requiring blanket** - Rocky beds, except those, which are very susceptible to weathering, e.g., rocks consisting of shale and other soft rocks, which become muddy after coming into contact with water; Well-graded gravel (GW); Well-graded sand (SW); Soils-conforming to specifications of blanket material.

### 1.2.7 Railway embankment failure

A railway embankment could fail in time in the following cases: failure of the natural ground; failure of the fill material in the embankment; failure of the formation top.

Failure of the railway embankment will present symptoms as follows: variation in cross levels; loss of ballast; overturning earth embankment beyond toes of the embankment; slips in bank slopes

**Ground Failure** - The natural ground on which embankment is made can fail either due to shear effect. Shear failure of natural ground generally takes place short time after construction or even when construction is in progress. Once the ground stabilizes, it hardly fails under existing embankments.

Remedy measures adopted to improve the load-carrying capacity of natural ground and accelerate the process of settlement.

- Provision of suitably spaced sheet or ordinary piles on either side of the embankment, which will check shear failure by obstructing the slipping mass.
- Provision of a balancing embankment to increase the load on the natural ground to check its heaving tendency.
- Provision of sand drains to help quicker consolidation.

**Failure due to embankments material** - shear failure and excessive settlement of an embankment conduct to the failure of filling material of the embankment.

This failure can be reduced by the selection of the fill material, better construction procedures, and adopting a suitably designing section.

The main reasons for this type of failure are the following:

- Over range stress in the soil, exceeding its safe limit, caused by heavy traffic;
- Side slopes of the bank with inadequate angle;
- Draining of water in the embankment, results increasing the weight of the soil and reducing its bearing capacity and shear resistance.
- Shear failure of existing embankments is frequently and occurs due to slips.
- Other causes of failure are the weights of the embankment and the moving loads on it. The forces resisting the failure are the cohesion and internal friction of the fill material.

The remedies considered for failures of this kind:

- Providing vertical piles on the slope on either side of the track, spaced at suitable intervals; this procedure help check shear failure by causing an obstruction for the slip mass.
- Levelling the side slopes.
- Reducing the height of the embankment.
- Providing a lighter material at the top of the embankment.
- Providing quality drainage.

**Failure of top formation** – this type of failure is very frequent in clayey soils after heavy rains. The following are causes:

- **Low capacity to support for the soil** - Sinking of the ballast and the track; the ballast punches into the formation causing ballast pockets.
- **Action of water and moving trains** - The top soil becomes soft resulting in the sinking of the ballast; also loses its drainage property.
- **Negative effect of weather** – will develop cracks on the formation and the ballast sinks through the cracks, resulting in the settlement of the track. These failures present considerable problems in the maintenance of the track, affecting the track geometry and loosing quantities of ballast. This phenomena makes the maintenance process difficult and expensive.

### 1.2.8 Corrective measures

The bearing capacity of the soil is improved by the provision of a blanket of adequate thickness between the ballast and the formation with problems. The blanket should be of a non-cohesive

material with adequate bearing capacity. The filter blanket serves as a barrier for the upward movement of the clay. It also provides a porous medium to drain off the surface water. The blanket can be inserted by imposing a traffic block of four to five hours or by temporarily operating only one line.

An efficient remedy measure is to drill holes in sand piling, vertically inside and outside the rail to a depth of 2-3 m. The holes are then filled up with clean sand and the track is resurfaced. Sand piles compact the soil and provide mechanical support to the subgrade. The drainage of the subgrade also improves; water rises to the surface through the sand piles by capillary action and evaporates.

Surface drainage can be improved by diverting ground water, providing catch water drains, etc., as well as draining the sub-surface structure.

Grout of cement and sand is pumped into the embankment by pneumatic injections - cement grouting. The injection points are kept close to both ends of the sleeper. Pumping is continued until the grout appears through the ballast and reaches its top surface. Cement grouting is considered to be a very effective method of treating the subgrade. It fills the cracks, preventing the water from flowing into the subgrade, and seals off the moisture entering it. The soil is stabilized and develops better properties and strength.

### 1.2.9 Soil stabilization by geotextiles

The method of stabilization of soil using geotextiles has recently been developed in many countries. A layer of geotextile is laid directly below the ballast or is sandwiched between layers of sand. Geotextiles not only work as separators and filters, but also help drain the water and provide reinforcement to the soil bed. Geotextiles are made up of polymers and have the unique property of allowing water, but not soil fines, to pass through.

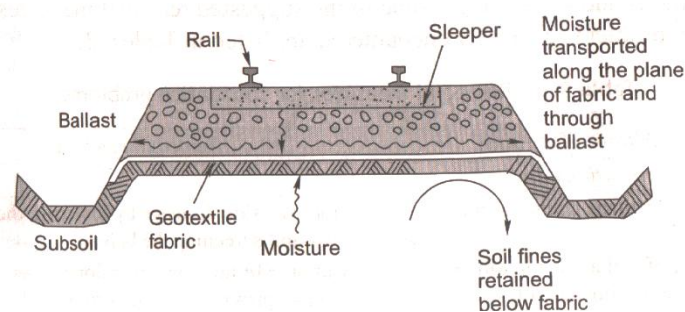

Figure 1.3 - Laying of geotextiles

## 1.3 Ballast

Ballast is an important component of track consisting of a layer of granular material provided below and around sleepers to distribute load from the sleepers over a larger area of the formation. A good ballast should provide drainage and longitudinal and lateral stability to the track. Any granular material can be used as ballast and placed and packed below and around sleepers for distributing the loading, if it satisfies certain requirements of strength, size, and gradation.

Ballast is used to give support, load transfer and drainage to the track and thereby keep water away from the rails and sleepers. Ballast must support the weight of the track and the considerable cyclic loading of passing trains. Individual loads on rails can be of around 50 tons for conventional lines and around 80 tons on a heavy haul freight line. (9)

The thickness of the ballast cushion under the sleepers depends upon the axle load, type of sleepers, sleeper density, and other related factors.

In time, ballast are broken in small pieces because of the dynamic action of the wheel load; for these reasons ballast requires regular maintenance.

Good ballast should meet the following characteristics:

- Should provide elasticity and resilience to the track for proper riding comfort.
- Should have the necessary resistance to the track for longitudinal and lateral stability.
- Have to provide a level and hard bed for the sleepers to rest on.
- Should have an effective means of maintaining the level and alignment of the track.
- Have to hold the sleepers in position during the passage of trains; it does not get crushed under the moving loads.
- Have capability to transfer and distribute load from the sleepers to a large area of the formation.
- It is capable of providing effective drainage to the track; it should be non-porous and should not absorb water.
- Ballast material has to have the following properties: tough, durable and wear resistant; hard so that it does not get crushed under the moving loads; free from weathered portions of parent rock, organic impurities, and inorganic residues; generally cubical with sharp edges; should resist both attrition and abrasion; it should be durable and should not get pulverized or disintegrated under adverse weather conditions; it should allow for good drainage of water; it should be cheap and economical.

### 1.3.1 Ballast types

**Sand ballast** - coarse sand is preferred against to fine sand; used primarily for cast iron (CI) pots. It is mainly used with wooden sleepers in areas where traffic density is very low. It has good drainage properties, but has the negative characteristic to disperses, being light. It also causes excessive wear of the rail top and the moving parts of the rolling stock.

**Coal ash or cinder** - This type of ballast is normally used in yards and sidings or as the initial ballast in new constructions since it is very cheap and easily available. It has corrosive effects for steel sleepers and fittings.

**Broken stone ballast** - A good stone ballast is generally procured from hard stones such as granite, quartzite, and other hard rocks. The quality of stone should be such that it is not porous and does not flake off due to the unpredictable events of weather. High-speed tracks have to use good quality stone. This type of ballast works out to be economical in the long run. This type of ballast will better resist movement.

**Other types of ballast** - There are other types of ballast also such as the brickbat ballast, gravel ballast, and even earth ballast. These types of ballast are used only in special circumstances.

Type of ballast	Advantages	Disadvantages	Suitability
Sand ballast	<ul style="list-style-type: none"> <li>• Good drainage properties;</li> <li>• Cheap;</li> <li>• No noise produced on the</li> </ul>	<ul style="list-style-type: none"> <li>• Causes excessive wear;</li> <li>• Blows off easily;</li> <li>• Poor retentively of packing;</li> </ul>	<ul style="list-style-type: none"> <li>• Suitable for CI pot sleeper tracks;</li> <li>• Not suitable for high-speed</li> </ul>



Type of ballast	Advantages	Disadvantages	Suitability
	<ul style="list-style-type: none"> <li>track;</li> <li>Good packing material for Cast Iron (CI) sleepers;</li> </ul>	<ul style="list-style-type: none"> <li>Track cannot be maintained to high standards;</li> </ul>	<ul style="list-style-type: none"> <li>tracks;</li> </ul>
<b>Coal ash or cinder</b>	<ul style="list-style-type: none"> <li>Easy availability on railways;</li> <li>Very cheap;</li> <li>Good drainage;</li> </ul>	<ul style="list-style-type: none"> <li>Harmful for steel sleepers</li> <li>Corrodes rail bottom and steel sleepers</li> <li>Soft and easily pulverized;</li> <li>Maintenance is difficult</li> </ul>	<ul style="list-style-type: none"> <li>Normally used in yards and sidings;</li> <li>Suitable for repairs of formations during floods and emergencies;</li> <li>Not fit for high - speed tracks;</li> </ul>
<b>Broken stone ballast</b>	<ul style="list-style-type: none"> <li>Hard and durable when procured from hard rocks;</li> <li>Good drainage properties;</li> <li>Stable and resilient to the track;</li> <li>Economical in the long run;</li> </ul>	<ul style="list-style-type: none"> <li>Difficulties in procurement;</li> <li>Angular shape may injure wooden sleepers;</li> </ul>	<ul style="list-style-type: none"> <li>Suitable for packing with track machines;</li> <li>Suitable for high-speed tracks;</li> </ul>

**Table 1.1 - Comparison of different types of ballast (9)**

### 1.3.2 Sub-ballast provision

The sub-ballast is a layer made of granular material and is laid between the formation and the ballast having role to distribute the train loads equally on the formation.

The material should consist of coarse granular substances such as river gravel, stone chips, quarry grit, and predominantly coarse sand, material should be non-cohesive. Ash, cinder, and slag containing predominantly fine and medium sand should not be used.

### 1.3.3 Self-stabilizing track

The railways use rails fixed on sleepers with double elastic fastenings and concrete sleepers over ballast bed. The ballast should provide the necessary self-draining, load distributing, as well as geometry correction medium. The ballast under the action of moving trains are affected by inherent vibrations and the geometry is disturbed as the ballast loses its compactness and yields.

The Indian Railways has developed this new technology with great results: “Self-Stabilizing Track” (SST) which will make the railway tracks safer by considerably reducing the vibrations in the track, by maintaining stable track geometry, and thus reducing chances of a derailment.

Normally, speeding trains cause vibrations that destabilize the ballast, thus disturbing the track geometry in the case of conventional method. The SST aims to change frequency response spectrum of ballast in such a manner that the ballast gets more and more stabilised under traffic.

In the new concept of self-stabilizing track running trains create conditions so that the track gets stabilized with the help of ballast. This is done by suitable control of the inertia of mass ballast that vibrates in track.

In the self-stabilizing track, predetermined quantities of ballast are pre-compacted and firmly constrained. Further, an elastic medium in the form of reinforced rubber or polyethylene layer of the order of a few millimetres thick, inserted between the sleeper bottom and the top of the constrained ballast.

The resulting effect is reducing the frequency and amplitude of vibrations being transmitted below the sleeper because of moving train. The ballast will not be disturbed and the formation will be protected from destabilizing vibrations.

The ballast is constrained in pre-formed wire mesh cages of specific shapes arranged in a particular manner to provide elastic vertical support to the sleeper as well as improved lateral resistance to the track.

This technology will make the tracks almost maintenance free, producing economic savings. With this technology for ballast could save up to 70 % of maintenance costs. It is evaluated that the initial cost adopting this technology is approximately to cost 10 % - 15% more than the conventional system, it could be reduced considerably with better management of the activities and production at large scale.

## **1.4 Sleepers (Ties)**

Sleepers are the transverse ties that are laid to support the rails. They have an important role in the track as they transmit the wheel load from the rails to the ballast.

The main functions of sleepers are as follows:

- Holding the rails in their correct gauge and alignment;
- Giving a firm and even support to the rails;
- Transferring the load evenly from the rails to a wider area of the ballast;
- Acting as an elastic medium between the rails and the ballast to absorb the blows and vibrations caused by moving loads;
- Providing longitudinal and lateral stability to the permanent way;
- Providing the means to rectify the track geometry during their service life.

The sleepers mostly used: wooden sleepers, cast iron (CI) sleepers, steel sleepers, and concrete sleepers.

### **1.4.1 Wooden Sleepers**

Traditionally sleepers (known as ties in the US) are wooden. They can be softwood or hardwood. Sleepers are normally impregnated with preservative and, under good conditions, will last up to 25 years. They are easy to cut and drill and used to be cheap and plentiful. They are becoming more expensive and other types of materials have appeared, the best being concrete and steel sleepers. The main negative aspects are short life due to wear, decay, and attack by vermin; difficult to maintain the gauge; susceptible to fire hazards; negligible scrap value.



Figure 1.4 – Wooden sleepers track <sup>3</sup>

For increasing intrinsic characteristics, treatment is applied for wooden sleepers, mostly to softwood types. This treatment includes pressure process as the preservative solution is forced into the wood, under pressure.

**Sleepers Seasoning** - Wooden sleepers are seasoned to reduce the moisture content so that their next treatment is effective. The seasoning of sleepers can be done by any one of the following processes:

- **Artificial seasoning in kiln** - This is a controlled method of seasoning the wood, normally used in USA and other countries, under conditions of temperature and relative humidity, which are in the range of natural air seasoning.
- **Boiling under vacuum process** - This is a procedure in which wood is treated with hot preservative to remove the moisture content.
- **Air seasoning** - The sleepers are stacked in the timber yard and a provision is made for enough space for the circulation of air in between the sleepers.

---

<sup>3</sup> <http://irishrailwaymodeller.com/showthread.php/484-gswr-101/page5>

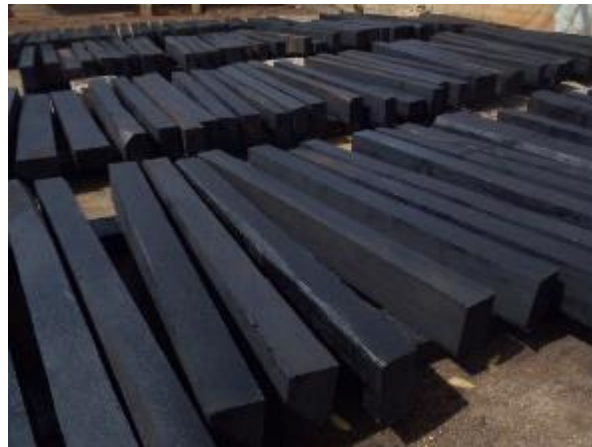

Figure 1.5 – Seasoning of wooden sleepers <sup>4</sup>

#### 1.4.2 Cast Iron Sleepers (CI)

Considerable advantages: less corrosion; less probability of cracking at rail seat; easy to manufacture; high scrap value.

Cast iron sleepers also have disadvantages: susceptible to metal breakage; the shocks and vibrations are directly transmitted to the ballast, resulting in poor retention of packing (loose packing) and hence an increased frequency of attention and inspection; gauge maintenance is difficult if the bars get bent; provides less lateral stability; unsuitable for track-circuited lines; the sleeper has only limited longitudinal and lateral strength to hold long welded rails (LWR), particularly in the breathing length.

#### 1.4.3 Concrete Sleepers

In the early period of history of railways, wood was the only material used for making sleepers in Europe. With the development of concrete technology in the nineteenth century, cement concrete became versatile building material that could be adopted as railway sleeper manufacturing. In 1877, Monnier, a French gardener and inventor of reinforced concrete, suggested that cement concrete could be used for making sleepers for railway tracks. Monnier designed a concrete sleeper and obtained a patent for it. The design was further developed and the railways of Austria and Italy produced the first concrete sleepers with a promising design around the nineteenth century. Other European railways followed this technology and manufacturing of concrete sleepers were done on large scale, mostly due to economic considerations.

---

<sup>4</sup> [http://www.montaracontinental.com/railway\\_sleepers.html](http://www.montaracontinental.com/railway_sleepers.html)



Figure 1.6 - Concrete sleepers <sup>5</sup>



Figure 1.7 –Installing concrete sleepers

Concrete sleepers have high strength and a long life, and are most suitable for modern tracks. As a result of extensive research carried out by French Railways and other European railways, the modern track adopted concrete sleepers along with heavier rail sections and long-welded rails. These conditions gave an opportunity to the development of concrete sleepers and countries such as France, Germany, and Britain started to develop performant types of concrete sleepers.

Concrete sleepers are much heavier than wooden sleepers; they better resist rolling stock movement and loading. However, they offer less flexibility, are alleged to crack more easily under heavy loads where the ballast is stiff. Another disadvantage, concrete sleepers cannot be cut to size for turnouts and special track work. A concrete sleeper can weigh up to 320 kg compared with a wooden sleeper which weighs about 100 kg but the spacing between concrete sleepers is about 25% greater than for wooden sleepers.

---

<sup>5</sup> Image taken in Northern Denmark (Hjørring - Hirtshals line); Author Tomasz Sienicki

## 1.5 Rail

Rails are the most important element of the track, laid in two parallel lines to provide an unchanging, continuous and level surface for the movement of trains. To be able to support stresses, they are made of high-carbon steel.

Rails perform the following functions in a track:

- They serve as a lateral guide for the wheels.
- Provide a continuous and level surface for the movement of trains and have to provide a pathway which is smooth and has very little friction comparative with the friction of the pneumatic tire in road transportation.
- They support the stresses developed from vertical loads, transmitted to them through axles and wheels of rolling stock as well as due to braking and thermal forces.
- They carry out the function of transmitting the load to a large area of the formation through sleepers and the ballast.

### 1.5.1 Types of rails

The first rails used were double headed (DH) and made of an “I” or dumbbell section. The idea was that once the head wear out, during service, the rail could be inverted and reused. Experience showed that the bottom surface of the rail was affected to such an extent because of long and continuous contact with the chairs that it was not possible to reuse it. This led to the development of the bull headed (BH) rail, which had an almost similar shape but with more metal in the head for better withstand wear and tear.

A flat-footed rail, also called a vignole rail with cross section of inverted T- type was developed, this type could be fixed directly to the sleepers with the help of spikes.

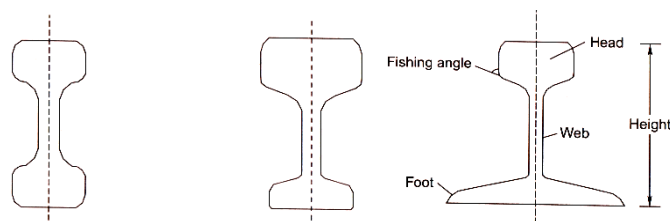

Figure 1.8 - Double headed rail, bull headed rail, flat-footed rail

But the main advantage of the flat-footed rail is that it is a more economical design, giving greater strength and lateral stability to the track as compared to a BH rail for a given cross-sectional area.

Rail consists of head, web, and foot as components should be balanced distribution of metal in its various components to achieve requirements.

The requirements, as well as the main considerations, for the rail components (see Figure 1.8) are:

- The head of the rail should have adequate depth to allow vertical wear and the desired lateral stiffness.
- The web should be sufficiently thick so as to withstand the stresses arising due to the loads borne by it, after allowing for normal corrosion.

- The foot of rail has to have sufficient thickness to be able to withstand vertical and horizontal forces even wearing due to corrosion.
- The fishing angles must ensure proper transmission off loads from the rails to the fish plates. The fishing angles should be such that the tightening of the plate does not produce any excessive stress on the web of the rail.
- The height should be adequate so that the rail has sufficient vertical stiffness and strength as a beam.

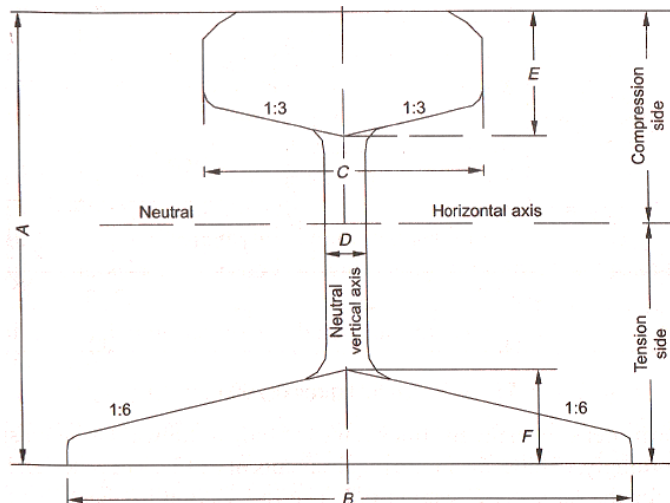

Figure 1.9 - Standard flat-footed rail section

Flat bottom rails can also be "spiked" directly to the sleepers. A wide headed nail is driven into the sleeper on each side of the rail so that the foot of the rail is held by the heads of the spikes, this is for conventional railways but the heavier loads and faster trains require more sophisticated systems.

To achieve good performances, the rail is welded into long lengths, which can be up to several hundred metres long. In this case, expansion rail is minimised by installing and securing the rails in tension. If the tension is adjusted to the correct level, to a suitable rail temperature level, expansion joints are not necessary needed.

The weight of a rail and its section is decided taking into consideration the following: heaviest axle load; maximum permissible speed; depth of ballast cushion; type and spacing of sleepers; other secondary factors.

### 1.5.2 Adopting of flat-footed rail

Network Rail as manager of railway infrastructure in the UK has adopted UIC60 which indicates that the rail which weighs 60 kg/m (125 lb/yd) should be standard for high speed lines.

For conventional lines the present standard is equivalent to the UIC 54 which states that weighs should be about 54 kg/m (113 lb/yd).

In the US, rail weight is related to railway categories: 80-90 lb/yd in small yards; 100-110 lb/yd. on light duty track; 130-141 lbs on heavy duty track. The 141 lbs rail is the new main line standard. The Pennsylvania Railroad uses a special 155 lb/yd. rail, which is considered the heaviest rail used for mainline operations.

Rail inclination – one characteristic of the European railways is to be slightly inclined inwards, to match the conic shape of the wheels. Rail inclination angles across Europe is in range from 1/20-1/40 with variations between countries. The angle of the rail inclination is provided either by the profile of the sleeper in the case of concrete and steel sleepers or as part of the rail fastening system on wooden sleepers.<sup>6</sup>

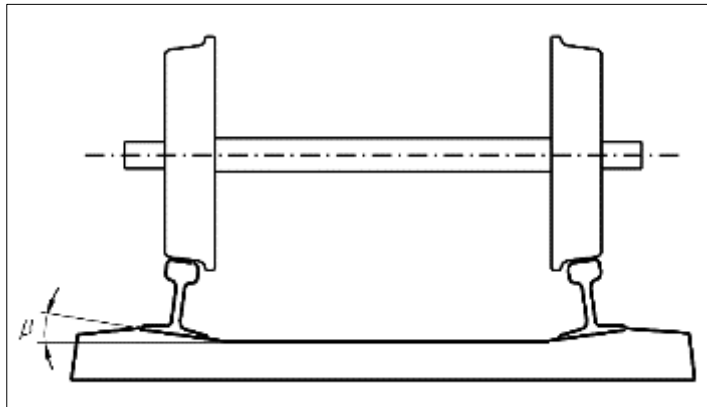

Figure 1.10 - Diagram showing rail inclination<sup>7</sup>

This is to ensure that under normal running the contact patch is at the top of the rail head and forces are transmitted vertically through the web of the rail.

## 1.6 Rail degradation and failure mechanisms

Particular attention in this analysis is given types of wear and failure due to their importance. Also, are analysed the locations of the track where the wearing is considerable.

The degradation of rail is a major cause of maintenance and renewal for all railways. To enable rail grade selection guidelines to be developed, a detailed understanding of the performance of the available rail steels under different loading conditions is required.

Due to the passage of moving loads and friction between the rail and the wheel, the rail head gets worn out in the course of service. The impact of moving loads, the effect of the forces of acceleration, deceleration and braking of wheels, the abrasion due to rail-wheel interaction, the effects of weather conditions such as changes in temperature, snow, and rains, the presence of materials such as sand, etc., cause considerable wear and tear of the vertical and lateral planes of the rail head. Lateral wear occurs more on curves because of the lateral centrifugal force. A lot of the metal of the rail head gets worn out, causing the weight of the rail to decrease. When loss of weight of the rail section exceed their permissible values, rail should be renewed.

A rail may face wear and tear in the following positions:

- Vertical wear - on top of the rail head.

<sup>6</sup> <http://www.era.europa.eu/Document-Register/Documents/IU-INF-TSI%20Final%20report%20annex-090902-%204.0.pdf>

<sup>7</sup> <http://dx.doi.org/10.1007/s11044-010-9217-8>



- Lateral wear - on the sides of the rail head.
- Battering of rail ends - on the ends of the rail.

Locations where the wear is more prominent:

- Sharp curves, due to centrifugal forces.
- Steep gradients, due to the extra force applied by the engine.
- Approaches to railway stations, possibly due to acceleration and deceleration.
- In tunnels and coastal areas, due to humidity and weather effects.

Over the last 30 years monitoring of small sections of track has been carried out throughout Europe by both Infrastructure Managers (IM) and rail manufacturers. As part of InnoTrack, this data has been collated, analysed and used to derive rail degradation algorithms for wear and rolling contact fatigue (RCF) in the form of head checks. This understanding of rail degradation has been used to aid the development of rail grade selection guidelines to allow the use of premium grade rail steels in a cost effective manner.

Detailed site monitoring allows understanding of the performance of current and new rail steels under operational conditions, but the variability in results mean that it is difficult to compare behaviour for different rail steels installed on different curves, with different traffic patterns. Reasons for the variability are the nature of the railway operations and the difficulty in measuring important factors such as the different types of vehicles, weather, maintenance regime etc.

To overcome this spread in results, averages have been taken for the different rail grades over specific radii ranges. From these averages, equations have been derived that describe the wear and RCF behaviour of rails as a function of their grade and the radius range in which they are installed. An example is given in Figure 1.11 for the growth of rolling contact fatigue cracks demonstrating that they predominate at radii between 700 and 3000 m. The results also demonstrate the greater resistance of premium grade steels to RCF.

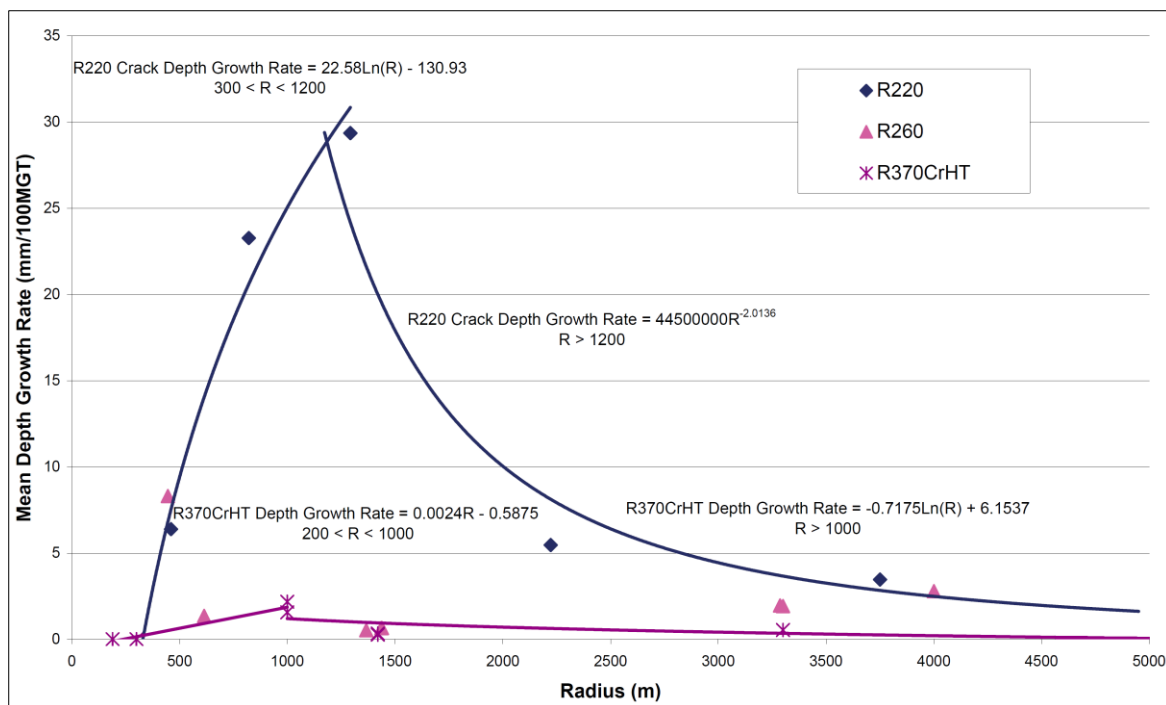

Figure 1.11 -Crack depth growth rate algorithms for different rail grades<sup>8</sup>

Methods adopted to reduce vertical wear and lateral wear on straight paths and curves:

- Better maintenance of the track to ensure good packing as well as proper alignment and use of the correct gauge.
- Reduction in the number of joints by welding.
- Use of heavier and higher tensile strength rails, which are more wear resistant.
- Use of bearing plates in case of wooden sleepers
- Lubricating the gauge face of the outer rail in case of curves
- Providing check rails in the case of sharp curves
- Interchanging the inner and outer rails
- Changing the rail by carrying out track renewal

Segmentation of a mixed traffic railway route has been carried out with the rail degradation algorithms applied to predict the degradation of each segment. This has been carried out in order to understand the relative importance of the different contributory factors and to demonstrate how the algorithms can be used to aid the development of rail grade selection criteria. This includes the effect on degradation of applying premium steels to all curves below a certain radii.

One of the most important wearing phenomena is the hammering action of moving loads on rail joints, named rail end batter. Due to the impact of the blows, the contact surfaces between the rails and sleepers also get worn out, the ballast at places where the sleepers are joined gets shaken up, the fish bolts become loose, etc. Rail end batter is measured as the difference between the height of

<sup>8</sup> InnoTrack Deliverable D4.1.4, Rail degradation algorithms, 2009

the rail at the end and at a point 30 cm away from the end. If the batter is up to 2 mm, it is classified “average”, but if it is between 2 and 3 mm, is classified as “severe”. When rail end batter is excessive but the rest of rail is in good condition, the ends can be cropped and the rail reused.

Rail lubricators are provided on sharp curves, where lateral wear is considerable. The function of lubricators is to oil the running face of the outer rail in order to reduce the friction. It has been noticed that this considerably reduces the wear, by up to 50 per cent. There are many mechanical devices that can be attached to the wheels to provide such lubrication. In these mechanical arrangements, the wheels of moving trains normally cause the lubricant to flow on the side of the rail either by the action of the wheels pressing the plunger up and down or from detection of movement of trains that causes lubricants to flow.

Rail ends get hogged due to poor maintenance of the rail joint, yielding formation, loose and faulty fastenings, and other such reasons. **Hogging of rails** causes the quality of the track to deteriorate. This defect can be remedied by measured shovel packing.

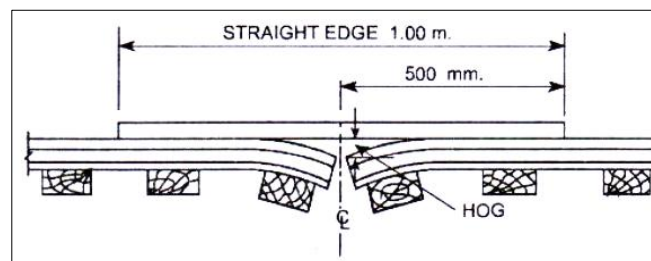

Figure 1.12 - Hogging of Rail – Method of measurement

Other wearing point of interest is **scabbing of rails** that occurs due to the falling of patches or chunks of metal from the rail table. Scabbing is generally seen in the shape of an elliptical depression, whose surface reveals a progressive fracture with numerous cracks around it.



Figure 1.13 - Scabbing of rail <sup>9</sup>

<sup>9</sup> [http://wiki.ircen.gov.in/doku/doku.php?id=derailment\\_case\\_studies](http://wiki.ircen.gov.in/doku/doku.php?id=derailment_case_studies)

**Wheel burns** are generally met on steep gradients or where there are heavy incidences of braking or near water columns. Wheel burns are caused by the slipping of the driving wheel of locomotives on the rail surface. As a consequence, extra heat is generated and the surface of the rail gets affected, resulting in a depression on the rail table.



Figure 1.14 - Burning of Rail <sup>10</sup>

### 1.6.1 “Minimum action” Rule

A “minimum action” rule acts as a principle and is the least that the responsible track engineer can do to ensure that the track remains safe on discovery of a broken or defective rail or weld.

All railway infrastructure managers (IM’s) undertake routine inspection, both visually and using non-destructive inspection techniques, such as ultrasonic or eddy current inspection. Once a defect has been found the problem arises whether its severity is an immediate safety risk or a long-term risk. The minimum actions are guidelines that specify the actions to be taken to ensure the integrity of the railway.

After initiation the cracks grow as time increases. Initially they are present but will not be discovered by inspection. Only when they have grown to a certain extent will they be detected either visually or by non-destructive inspection. On detection, the track engineer has to decide whether it is a current risk that requires immediate removal or if it will become a risk in the future. The minimum action rules are used as a guide for decision making in this kind of situation. They specify a timescale in which the defect has to be removed. During this period, the crack will continue to grow until it is removed. The aim of the rules is to ensure a margin of safety remains even at the end of the action timescale.

The work carried out within InnoTrack has been targeted at developing a scientific basis for minimum actions. To allow an understanding of the current situation across Europe a survey of the current minimum actions applied by the IM’s has been conducted.

An overview of the current minimum actions used by different IM’s shows that there is a considerable difference in their approach to defects. For the same type of defect, such as a squat, there is a wide range of timescales and emergency actions required. Similar variations in required actions are seen for a number of different defect types. With a mixed traffic railway, such as operated by the IM’s within the InnoTrack project, it would be expected that growth rates of defects will be similar, even when taking into account the different type of vehicles, track support stiffness, rail grades, profiles etc. The wide range of minimum actions encountered within Europe is thus likely to

---

<sup>10</sup> [http://www.kldlabs.com/?page\\_id=63](http://www.kldlabs.com/?page_id=63)

be, to a large extent, a result of historical experience with little scientific backing. There is therefore a requirement for a more solid scientific basis to be put in place behind the minimum actions to ensure that the railways remain safe especially under altered operational conditions. This would also allow a move towards preventive rather than corrective maintenance. The scientific approach also allows an understanding of the integrity of the railway resulting from a step change, such as a change in the inspection regime or the introduction of a slab track system.

The work in InnoTrack on minimum actions uses two different approaches. The first involves detailed modelling to understand how different types of defects initiate and grow under a range of loading conditions. The second develops prediction rules, to be able to tell when a crack reaches a critical size that may result in rail failure under real world conditions. It is through the combination of these approaches that new minimum actions can be proposed.

### 1.6.2 Corrugation of rails

Corrugation consists of depressions on the surface of rails, varying in shape and size and occurring at irregular intervals. The corrugation studied in InnoTrack consists of small amplitude undulations with wavelengths of the order of 1–10 cm on the running surfaces of wheels and rails. These can induce vibrations that cause rolling noise and vertical wheel – rail contact forces with frequency that in turn may cause subsurface initiated rolling contact fatigue (RCF) in wheels and rail.

The factors which are involved in the formation of rail corrugation, are the following:

- Steep gradients, yielding formation, long tunnels, electrified sections, environment conditions of track;
- Metallurgy and age of rails: high nitrogen content of the rails; effect of oscillation at the time of rolling and straightening of rails.
- Train operations: high speeds and high axle loads; starting locations of trains; locations where brakes are applied to stop the train;
- Atmospheric effects: high moisture content in the air particularly in coastal areas; presence of sand, etc.



Figure 1.15 - Corrugation on rail<sup>11</sup>

---

<sup>11</sup> <http://railmeasurement.com/>

The corrugation of rails is quite an undesirable feature. When vehicles pass over corrugated rails, a roaring sound is produced, possibly due to the locking of air in the corrugation. This phenomenon is sometimes called “Roaring of rails”. This unpleasant and excessive noise causes great inconvenience to the passengers. Corrugation also results in the rapid oscillation of rails, which in turn loosens the keys, causes excessive wear to fittings, and disturbs the packing.

Current regulations on the allowed limit vary throughout Europe and mainly consider the influence on noise generation. In the UIC series of technical and research reports, rail corrugation is included under topic D 185. The European norm EN 15610:2009 regulates measurements of corrugation.

The study has shown that an increase in corrugation can be expressed by the scaling of a corrugation spectrum. Using scaled corrugation spectra, parametric studies were carried out. The main conclusions were:

- A given speed increase will increase the maximum RCF loading and the noise emission.
- An increased axle load will increase the mean value of the RCF loading, but the load scatter due to the corrugation will decrease. Normally the result will be a net increase in maximum RCF loading.
- Limiting noise emissions requires harder limits on the rails for freight operations as compared to passenger traffic. The reason is how rougher wheels tread surfaces of rails, for freight transportation.

Acceptance criteria for rail corrugation have been developed in the following manner: Given the operational conditions sound pressure levels are evaluated for varying magnitudes of corrugation. The risk of RCF is assessed. Allowed rail corrugation magnitude is then defined as the highest magnitude for which noise emissions and RCF loadings are acceptable.

Corrugation can be removed by grinding the rail head with a fraction of millimetre. The problem of corrugation has been tackled in great detail on German Railways, where two types of equipment are normally used for rail grinding: Hand or motor-driven trollies that move on the rails at slow speeds and grind the individual rails at once; Rail grinding train, which moves at a speed of 30 km per hour and grinds both rails simultaneously.

### **1.6.3 Rail degradation mechanisms**

First of all, to analyse and optimize maintenance costs is necessary to know the causes and mechanisms of rails degradation.

The key degradation mechanisms that limit the serviceable/operational life of rail are: Loss of Rail Profile (vertical and lateral wearing; corrugation, etc.), Rolling Contact Fatigue (RCF); Rail Breakage.

Considering different degradation mechanism should be identified different solutions for reducing degradation. These solutions are basis on a combination of rail material properties. For this reason, a number of rail steel grades have been developed and are available to the industry with a range of different properties. On basis of analyses and simulation from InnoTrack, could be made recommendation of the appropriate rail grade for different sections of track;

Optimisation of other aspects of the systems design and operation need to be taken into consideration for optimisation because degradation is the result of the whole system

Any reduction in the stress levels within the contact patch through optimisation of rail wheel profile should be combined with improved rail metallurgy for maximum optimisation and benefits.

### 1.6.4 Loss of rail profile

This is main mechanism of degradation and is caused by wear and/or plastic deformation. This degradation mechanism causes increasing frequency of maintenance and even premature replacement of rail in track. The loss of profile includes both vertical and side wear of rails through the action of wheels on them.

Some examples of loss of rail profiles are shown in Figure 1.16:

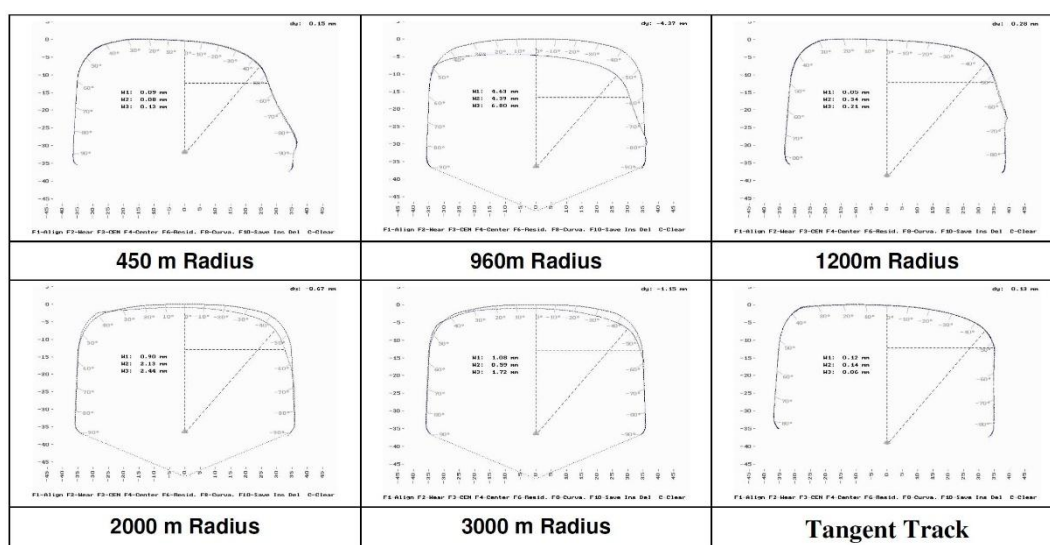

Figure 1.16 - Loss of Rail Profile casuistic<sup>12</sup>

As a consequence it is necessary to maintain the optimum rail profile for the different contact conditions for as long as possible but also should be developed and used rails of quality and hardened steels that minimise the loss of transverse profile.

The occurrence of corrugations is another source of wearing and could also be regarded as loss of rail profile in the longitudinal direction particularly.

### 1.6.5 Rolling Contact Fatigue (RCF)

Rails are permanent loading in service and for this reason the stress range and the magnitude of stresses are dependent by a range of variables: the rail profile, the wheel profile, the contact patch position, the contact area, and the dynamic track forces from the vehicle. Consequently, the phenomenon of fatigue becomes of critical importance to longevity of rails.

The two major classifications of rolling contact fatigue (RCF) are “squats” and “head checks” and could be associated with early propagation of surface or near surface initiated rolling contact fatigue cracks.

<sup>12</sup> (Source: InnoTrack - D4.1.2 Interim Rail Degradation Algorithms)



Figure 1.17 - RCF Cracks <sup>13</sup>

The stages in the life of surface initiated RCF cracks are:

- Crack initiation;
- Shallow angle crack;
- Turn down and growth of turned down cracks. In some cases, cracks can turn upwards and/or merge with neighbouring cracks to cause “shelling” which renders the rail not to be possible inspected and hence enforcing replacement.

RCF cracks can also be initiated sub-surface, an example of which is shown in Figure 1.18. Often such defects or breaks can be classified as “Tache Ovale” and attributed to presence of inclusions. Although, modern steelmaking practice has eliminated failures associated with inclusions, sub-surface fatigue cracks can still be initiated because of inappropriate contact conditions giving rise to high sub-surface shear stresses.



Figure 1.18 - Example of a Sub-surface Initiated RCF Crack <sup>14</sup>

---

<sup>13</sup> (Source: InnoTrack - D4.1.2 Interim Rail Degradation Algorithms)

<sup>14</sup> (Source: InnoTrack - D4.1.2 Interim Rail Degradation Algorithms)



Pearlites rail steels with higher hardness show in general a higher resistance against wear and RCF. The improvement for the head hardened grade R350HT compared to standard grade R260 is about 3 times for wear and 2 times regarding RCF.

The resistance to RCF of rail steels does not feature in any rail steel specification. However, in view of the growing acknowledgement by most railways that RCF is a key cause for rail life curtailment, it is essential to establish a measure of RCF resistance in terms of: period or cycles to initiation; growth rate of cracks during shallow angle stage; growth rate of cracks following turn down governed primarily by standard fracture mechanics principles.

Wear type loss of rail profile is dominant in curves with radii of less than 1000m. The results also indicate that RCF (the observed data limits this to so called “head checks”) is a problem that can occur over a radius range of 500 to 5000m.

### 1.6.6 Rail breakage

Rail breaks and defectives form the third category of rail degradation and fracture mechanics principles. This shows the importance of material properties, required to make rail steels more tolerant of in-service conditions. Rail breaks result from a number of causes including: rail foot corrosion; failure at rail ends, including room bolt holes; failure of welds; internal defects.

Failures from the various manifestations of RCF also pose an increased risk as indicated in the previous section.



Figure 1.19 - Rail breakage from a fatigue crack initiating at a corrosion pit <sup>15</sup>

The material properties relevant to the assessment of the risk of rail breakages are: fracture toughness; impact properties; fatigue crack growth rate; full rail section bending fatigue strength; defect size tolerance; level of residual stress in various parts of the rails.

---

<sup>15</sup> (Source: InnoTrack - D4.1.2 Interim Rail Degradation Algorithms)

### 1.6.7 External studies confirm InnoTrack results

The results from the site monitoring and the rail degradation data analysis in InnoTrack project, as general conclusions:

- Curves of low radius demonstrate higher wear than higher radius curves while the higher radius curves exhibit RCF.
- Harder rails are more resistant to wear and rolling contact fatigue than standard grade rails.

To maximise assets and minimise life cycle costs it is therefore vitally important that these premium grade rails are used at appropriate locations within track. This is the basis for the guidelines on the selection of rail grades. It is also important to note that the use of premium rail grades is not a replacement for effective maintenance. The maximum benefits will arise from an optimised lubrication and grinding strategy for the different rail grades.

From tests and based on results analyse have been determined that the use of the high strength/hardness heat treated rails are beneficial in combating both RCF and wear, therefore their use is recommended on curves with higher radius than have been previously recommended.

The results for the benefits of using harder rails have also been supported by a literature search of laboratory testing results. Based on track tests and site monitoring of wear and head checking, that have been reported in the literature external by the project, show in general similar results relative to degradation behaviour of rail steel grade, compared with a different one at specific test sites.

As examples of external literature that confirm conclusions of InnoTrack:

- Marich, S. and Mutton, P.J., (1989) have demonstrated decreasing wear rate by increasing rail hardness under conditions of moderate lubrication and more extensively lubricated rails. For example the standard carbon rail shows 2.5 times the wear rate than a head hardened one with moderate lubrication and nearly 2 times for the more extensive lubrication. The effect of lubrication in reducing wear is higher for the standard rail grade. (12)
- Results were reported by Muster, H. (1996) with slightly less benefit of a head hardened grade of hardness 370HB versus standard UIC900A (equivalent to R260). Where determined double the wear resistance without lubrication and less improvement for a lubricated curve (1.5 times). The hardened steel grade showed in general a 30% reduction in the depth of RCF cracks. At one lubricated location the standard rail grade had to be removed due to risk of degradation, while the 370HB rail remained in track and will be checked for degradation of rail head. (13)
- More recently Heyder, R. and Girsch, G. (2005) reported on tests performed on high-speed tracks of DB where the main degradation mechanism is head checking. On grade UIC800 (equivalent to R220) rails the depth of rail damage, due to head checks, was twice as much as for grade 900A (R260) and six times greater than for grade R350HT. The rails made of grade R350HT showed the lowest wear rate, which was about half of that for grade R260 and one-third compared to grade R220. It was also found that the wavelength and depth of corrugations could be reduced by the use of the harder rail grades. Similar results have been found on French mixed traffic lines where the harder heat treated rails were more resistant to both wear and RCF. (14)

Even if the absolute value of degradation rate will vary from site to site, as a general conclusion, with results from historic track tests reported in the literature, demonstrate that the use of high strength pearlitic rail steel grades reduce degradation due to wear and RCF crack growth, compared to standard grades. The consequence related to a proper rail grade selection is that less maintenance would be required and the total lifetime of the rails would increase.

### 1.6.8 Rail failure

When rail failed, it is considered necessary to remove it immediately from the track with reason of the defects stated for it. The majority of rail failures originate from the fatigue cracks caused due to alternating stresses created in the rail section on account of the passage of loads. A rail section is normally designed to take a certain minimum GMT of traffic, but sometimes due to reasons such as an inherent defect in the metal, the section becomes weak at a particular point and leads to premature failure of the rail.

**Rail failures causes** - The main causes of failure of rails are as follows:

- **Defects in welding of joints** - These defects arise either because of improper composition of the termite weld metal or because of a defective welding technique.
- **Improper maintenance of track** - Ineffective or careless maintenance of the track or delayed renewal of the track.
- **Intrinsic defects in the rail** - These are due to manufacturing defects in the rail, such as faulty chemical composition, harmful segregation, piping, seams, laps, and guide marks.
- **Defects due abnormal traffic effects** - Flat spots in tires, engine burns, skidding of wheels severe braking, etc.
- **Excessive corrosion of rails** - This generally takes place due to weather conditions, the presence of corrosive salts such as chlorides and constant exposure of the rails to moisture and humidity in locations near water columns, ash pits, tunnels, etc. Corrosion normally leads to the development of cracks in regions with a high concentration of stresses.
- **Badly maintained joints** - Poor maintenance of joints such as improper packing of joint sleepers and loose fittings.

## 1.7 Rail Grinding

Modern railway traffic operation provokes at many places (depending from local, operational conditions) a rail surface fatigue phenomenon, usually referred to as rolling contact fatigue (RCF). Head checks and similar defects develop sooner or later.

Rail grinding is considered the effective solution for maintenance and control of the effects of rolling fatigue; also, grinding remove rail undulations, restore rail profile and maximize rail life. Grinding of rails does not offer any permanent solution to the rail corrugations as the corrugations reappear and need grinding again

Since the oscillation caused by corrugations and waves exerts a considerable influence on the track maintenance costs and on the riding quality, it is absolutely necessary to remove these faults occurring on the rail surfaces and the running edges, to treat corrugation and waves and to provide a good longitudinal profile of rails.

During the grinding operation, vertical, horizontal, and angular movement of grinding unit have to be precisely controlled; in most advanced procedures are used computer controlled grinding machines.

Rail grinding can be generally classified into next following main types:

### 1.7.1 Initial grinding

This is done on rails that are new laid during new construction or after rail renewal. Initial grinding corrects construction damage and removes the decarbonised surface area of the rail head where the mechanical properties are poorer. The removal of 0.3 mm from the surface layer of the rail, guards against the damage to rail, which is likely to take place in the formation of squats.

Initial grinding of new rails in track is carried out for a number of reasons:

- Removal of mill-scale and rust;
- Removal of (minor) damage resulting from track construction work;
- Improvement of (minor) irregularities at welds;
- Optimization of the transverse profile (reduction of deviations from production tolerances of all track components);
- Application of specific target profiles (if not milled), such as asymmetric profiles, anti-head check profiles, gauge widening profiles etc.

The positive effects result in reduced forces and vibrations (perfect and smooth longitudinal profile) and optimized contact conditions which both contribute to delay and reduce onset of surface problems (corrugation in the longitudinal plane and surface fatigue).

#### Present situation

Initial grinding is done with all newly constructed lines (in particular high-speed). It is also done after renewal of long sections of rail. Due to operational restrictions it may be executed up to 6 months after re-railing.

Specifications usually demand a (minimum) metal removal of 0.3 mm, as-rolled profiles and symmetric tolerances (e.g. +/-0.3 mm).

Some IM have started to specify specific target profiles (wear adapted – BV, low conicity profiles – ÖBB) and request negative tolerances (e.g. 0/-0.6 mm) in case of expected gauge corner fatigue (DB AG, BV). (16)

#### Potential improvement

As a rule grinding should always be carried out as soon as possible after re-railing. The target profile should always be optimized, e.g. “anti-head check-profiles” with adapted production tolerances (usually only negative) or wheel-adapted profiles.

### 1.7.2 Corrective grinding

This is based on symptom-related interventions. Activities are directed by monitoring damage against present levels as removing short pitch corrugation once it reaches a 0.05 mm depth.

Rail grinding will help in reduction of fractures and defect rate. The railway track will get desired rail profile through rail grinding and will reduce stress concentration at same spots, thereby extending the life. It is assumed that from same rail, railway may get double the life.

The rail steel quality plays a determining role, but there is no material available at present, which can prevent the development of RCF cracks. Furthermore, the majority of rails in track today, with adequate but lower fatigue resistance, have a residual life span, which makes it much more economic to maintain them in an appropriate manner rather than to replace them. Thus, rail maintenance is an inevitable must.

### 1.7.3 Preventive Grinding

The preventive grinding is done at a stage when have to treat the rail when damage is at the initial stage. In Europe – apart from some exceptions (see below) - there are no specific and harmonized grinding strategies applied. Grinding is mainly executed to control corrugation and related noise problems.

Occasionally, but in a growing number, grinding is executed, when RCF seems to be more severe. Exceptionally, some IM have started to program grinding work in fixed (shorter) intervals. European wide accepted specifications do not exist yet. Current practice varies from 0.2 mm metal removal at shorter intervals (15 – 30 MGT), complete damage removal (which is not checked) to partial damage removal (no values specified), special target profiles (usually designed from experience) become more widely used.

Basic problem is the influence of the available grinding budget, which is usually insufficient in order to apply a more strategic maintenance regime. Short time considerations (repair of damaged components) dominate over a long term approach (prevention of damage to reduce LCC).

DB AG and ProRail (Netherlands) use rail inspection trains equipped with an eddy current detection unit. This unit is able to examine the rails with inspection speeds of up to 100 km/h. The eddy current testing with the rail inspection train, which is currently undergoing trials, will be incorporated into the scheduled rail inspection programmed in the near future. After the assessment the results of the combined eddy current and ultrasonic testing with rail inspection trains, this process will be the basis of planning maintenance activities for rails with head checks.

The represented IM's have already specified strategic actions based on their local conditions and experiences. They differ in detail but have a basic common approach.

**DB (Deutsche Bahn) AG** - In 2008 a preventive cyclic rail grinding program has started for rails in curves with radii from 500 to 5.000 m for lines with high capacity (40 % of the whole network). Preferred action is rail machining with a metal removal of 0.5 mm. The machining interval depends on the load of the track per year and varies from 0.5 to 2 years. Target profile is 60E2 with an inclination of 1:40 with only negative tolerances (0 to -0.6 mm). The installation of an anti-head check-profile (e.g. 60E2 1:40 with 0.6 mm undercutting at the gauge corner and with symmetric production tolerances of +/- 0.3 mm) is under discussion.

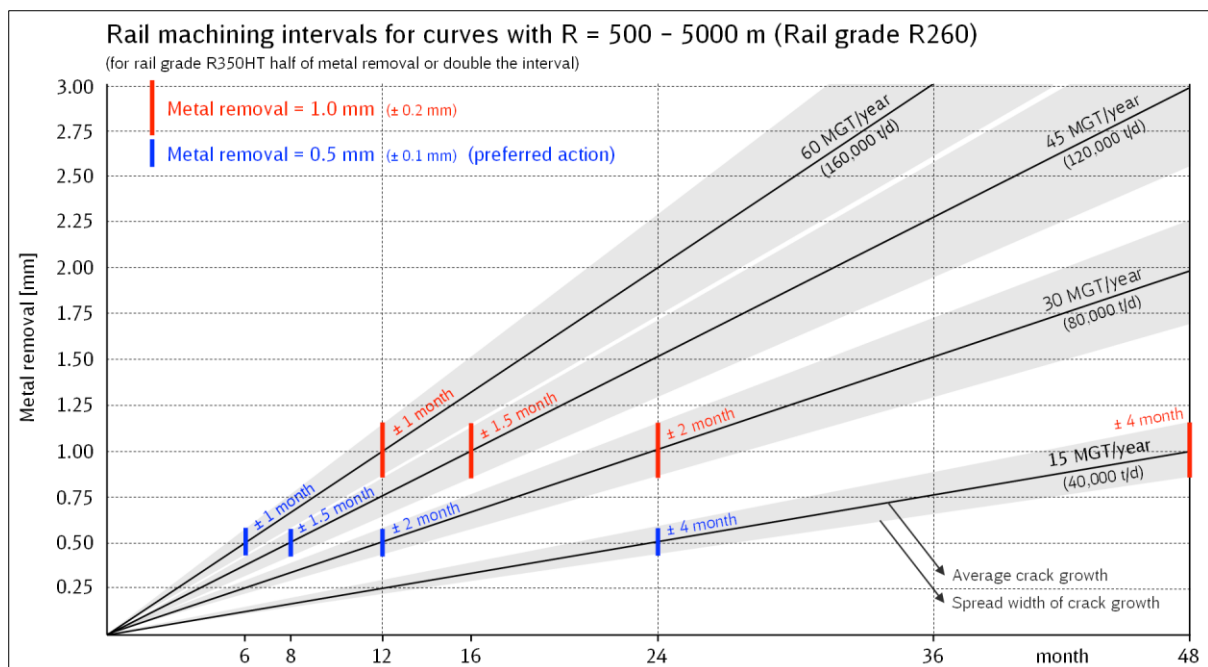

Figure 1.20 - Specifications for DB preventive cyclic rail machining program started in 2008 for rails in curves with radii from 500 to 5.000 m for lines with high capacity in the DB network<sup>16</sup>

**SNCF** - Until 2007 rail maintenance was done in a corrective mode as follows:

- On conventional lines treatment was programmed when defects (head checking) could be visually detected or influences in track geometry became apparent.
- On high-speed-lines rail grinding was executed when ballast stone imprints or head checking occurred.

SNCF Infrastructure Maintenance Division has undertaken an econometric study<sup>17</sup>. Consequently a new maintenance strategy are implemented from 2008:

- Preventive cyclic grinding first on lines UIC groups 1 to 4 category and then 5 and 6.
- Gradual reduction of the amount of corrective work (the corrective treatment becomes exceptional);
- Continuous treatment of lines with flexible metal removal according to the rail condition assured by variable grinding speed, the final aim being a constant one;
- Programming grinding activities on cycles.

With long term programming (interventions are known years ahead) longer possession times can be organized in order to increase productivity of grinding sites and thus reduce costs;

<sup>16</sup> [http://www.innotrack.net/IMG/pdf/innotrack\\_concl\\_20techn\\_report\\_lowres.pdf](http://www.innotrack.net/IMG/pdf/innotrack_concl_20techn_report_lowres.pdf)

<sup>17</sup> "Impact of preventive grinding on maintenance costs and determination of an optimal grinding cycle" (C. Meier-Hirmer, Ph. Pouligny).

**ProRail** - Preventive cyclic grinding has been started at 2005 by adoption of the Canadian grinding policy (NRC). Before coming in the preventive cyclic grinding mode, it was important to reach a zero level by corrective grinding when necessary. In Holland it takes 2 years of planning grinding capacity to reach the preventive cyclic grinding policy 100% for straight track and curves.

For the switches ProRail started in 2007 to grind in the Anti Head Check profile. Preventive cyclic grinding for switches focused on the straight part and not the curved side.

**Grinding frequency (based on tonnage of track and switches):**

- 15 MGT Radius  $R < 3000\text{m}$ ;
- 30 MGT Radius  $3000 < R < 9000\text{m}$ ;
- 45 MGT Radius  $R > 9000\text{m}$ ;

**Target profiles:**

- Straight track: 54 E1 profile;
- Curves (upper leg) and switches: 54 E1 AHC (Anti Head Check) profile;

**Metal removal:**

- Minimum of 0.2 mm within one grinding pass

#### 1.7.4 Conclusions for grinding procedure

Reason for grinding is corrugation, Rolling Cycle Fatigue (RCF) or vehicle stability; they do not overlap usually. Each railway has specifications for rail grinding work; target profiles for grinding are specified. Apart from a standard profile special profiles are defined, in particular to deal with gauge corner fatigue. Some railways specify grinding cycles. In case of RCF gauge corner relief is specified generally. Combination of grinding with other track maintenance work, in particular tamping before grinding is

The introduction of the preventive cyclic grinding strategy has resulted in a reduction of rail maintenance costs of about 50 %. A similar approach at the wheel side (introduction of anti-head check wheel-profiles and regular wheel turning) has resulted in a reduction of wheel maintenance costs by some 30 %.

Rail grinding on curved track is carried out to manage the rail profile and provide a consistent running band towards the crown of the rail (gauge corner shoulder relief). This is required more frequently due to the more rapid deterioration and loss of the ground rail profile as a result of side wear.

Rail grinding on straight track is undertaken to control corrugation and squats, to maintain a near new rail profile and to give a variation to the shoulder relieved profile used on the high rail of curves. This is required less frequently as wear rates and profile deterioration is much lower.

Where RCF exists, grinding of long sites is undertaken using a grinding train so as to produce a uniform running band towards the crown of the rail and to relieve load from the cracked area and slow the development of the existing cracks.

Where grinding is being used regularly on new rail, this will provide an improved profile and remove the fatigue damaged surface layer and reduce the rate at which the profile deteriorates. The profiles, frequency and minimum metal removal rates have been developed to slow down or stop the rate at which cracks initiate and grow.

### **1.7.5 Potential improvement through preventive actions**

Head check-detection systems have been developed and are now also available on rail grinding machines. These systems allow to checking the defect depth. Thus a certain damage level could be accepted (as intervention threshold or as remaining depth after treatment) - small enough to be removed in a short time and not interfering with safety issues – and of a certain dimension not to intervene too often – in order to reduce interference with traffic.

When establishing a strategic head check controlling approach, logistical issues need to be addressed as well: Grinding interventions require track possession time. If the used grinding technology matches all the requirements high production rates at comparatively low prices can be expected.

When working in cycles (for any given surface problem) all other irregularities such as corrugation, imprints, squats etc. will be controlled or eliminated simultaneously and their negative effects will be removed equally.

Usually grinding concentrates on problematic areas often dispersed geographically. As depots for the grinding machines are located at considerable distances (sometimes over 100 km), the grinding machines have to be transferred every day over long distances (as low priority trains), thus useful working time is lost. Due to the need to organize possession intervals for the execution of work further time is lost for organization and waiting during the work shift.

In order to move from the present corrective maintenance regime to a preventive cyclic, the following steps are proposed in InnoTrack:

- Measure and document the actual situation with regard to rolling contact fatigue.
- Classify the track sections in the following categories: preventive cyclic work sufficient; corrective work required; heavily damaged (to be replaced in due time).
- Prioritize required corrective actions: corrective to zero (preventive mode) in one step – it is preferred scenario; corrective to zero (preventive mode) in several steps - (If budget or grinding capacity limited); keep present situation by preventive cyclic interventions - (minimal solution).
- In any case keep all existing and corrected sections in preventive cyclic mode.
- Prioritize preventive cyclic work over corrective work.

RCF grinding should be programmed strategically; a regular (preventive cyclic) grinding program should cover a whole line. Possession times should be organized accordingly. Depots should be adapted to the maintenance requirements of the machines which should be available at strategic points.

An ideal maintenance plan would provide that the grinding machines (size to be adapted to required metal removal in a one-pass operation) starts from the first depot and moves over the line in order



to grind wherever required. The working speed would be dependent on the required metal removal (mind cycle) and could vary from 3 km/h (exceptionally in case of more severe defects) to a maximum of 20 km/h (at present grinders are limited at about 10 km/h). With an average grinding speed of 10 km/h it should be possible to achieve a production rate of up to 50 km per day.

Grinding work reduces dynamic forces and vibrations and thus helps to reduce track degradation. It should therefore be - whenever possible - coordinated with other track maintenance activities, e.g. whenever tamping work is required, it should be checked whether existing corrugation should be removed in connection, preferably after tamping. Suitable machines providing the required production capacity need to be considered.

## 1.8 Linking rails – rail joints and rail welding

### 1.8.1 Rail Joints Necessity

A rail joint is a necessary feature of railway tracks, even though it presents a lot of problems in the maintenance of the permanent way; fish plated joints are particularly weak. Rail joints are used to join rails in series and for this reason are an integral part of the railway track. Due to difficulties in packaging and the problem of transportation, rails are rolled in short lengths; while temperature increasing, the rails expand and this expansion needs to be compensated for at the joints. It was, therefore, felt that the longer the rail, the larger the required expansion gap, and this too limited the length of the rail.

There is a break at a joint in the continuity of the rail, in both the horizontal and the vertical planes, because of the presence of the expansion gap and imperfection in the levels of rail heads. The fittings at the joint may also become loose, causing heavy wear and tear of the track material.



Figure 1.21 - Rail Joints Example at RCCF partner

Some of the problems associated with the rail joint are as follows:

- Due to the impact of moving loads on the joint, the packing under the sleeper loosens and the geometry of the track gets distorted very quickly because of which the joint requires frequent attention; that means an increased maintenance effort.
- Even though it is not excessive, it should be considered that the locomotive will increase fuel consumption of the extra effort required to haul the train over these joints.

- Life cycle of rails, sleepers, and fastenings gets adversely affected due to the extra stresses created by the impact of moving loads on the rail joint. The rail ends particularly get battered and hogged and chances of rail fracture at joints are considerably high due to fatigue stresses.
- Track quality suffers because of excessive wear and tear of track components and rolling stock caused by rail joints.
- Noise pollution is created due to rail joints, making rail travel uncomfortable.

### 1.8.2 Rail Joint classification

The nomenclature of rail joints depends upon the position of the sleepers or the joints.

Classification based on the position of joint:

- **Square joint** - In this case, the joints in one rail are opposite to the joints in the other rail.

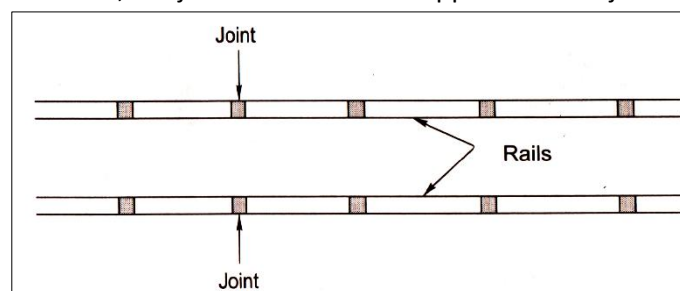

Figure 1.22 - Square joint

- **Staggered joint** - the joints in one rail are somewhat staggered and are not opposite the joints in the other rail. Staggered joints are normally preferred on curved tracks because they hinder the centrifugal force that pushes the track outward

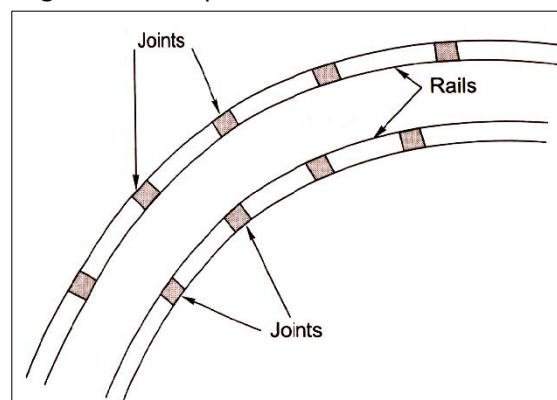

Figure 1.23 - Staggered joint

Classification based on position of sleepers:

- Supported joint has the ends of the rails which are supported directly on the sleeper; the support tends to raise the height of the rail ends.

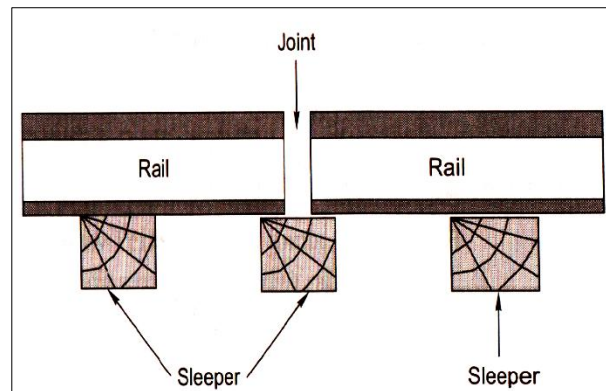

Figure 1.24 - Supported rail joint

- Suspended joint - In this type of joint, the ends of the rails are suspended between two sleepers and some portion of the rail is cantilevered at the joint. The packing under the sleepers of the joint becomes loose particularly due action of the moving train loads. Suspended joints are the most common type of joints adopted by railway systems worldwide.

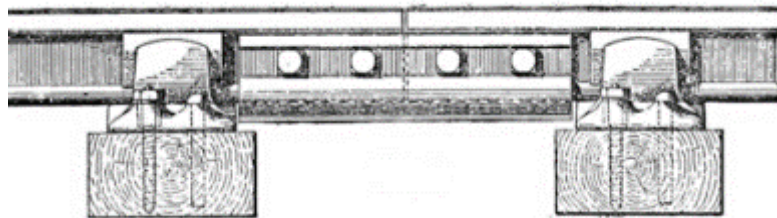

Figure 1.25 - Suspended joint<sup>18</sup>

- Bridge joints - The bridge joint is similar to the suspended joint except that the two sleepers on either side of a bridge joint are connected by means of a metal flat or a corrugated plate known as a bridge plate.

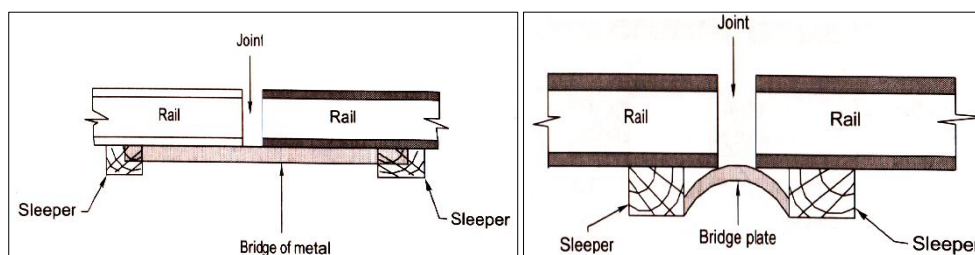

Figure 1.26 - Bridge joint with metal flat and with bridge plate<sup>19</sup>

### 1.8.3 Rail joint welding

The goal of welding is to join rail ends together by a specialized welding process and in this manner to eliminate the negative effects of rail joints.

<sup>18</sup> <https://archive.org/stream/>

<sup>19</sup> Satish Chandra; M.M. Agarwal – Railway Engineering (Second Edition); 2013

There are four welding methods used in railways around the world: Flash Butt welding; Metal electric arc welding; Gas Pressure welding; and Thermite welding.

In Europe, welding of rails is mainly achieved by using two different methods, aluminothermic welding and flash butt welding. Both processes are well experienced and have high level of process reliability. Aluminothermic welding is a mobile welding procedure predominantly used for repair and maintenance of tracks and welding of switches and crossings. Traditionally, flash butt welds have been manufactured in depot welding machines but there are mobile welding units which is also available to undertake joining of rails in track. Flash butt welding is mainly used for the installation of new tracks and the renewal of tracks. Thus, the above two welding processes satisfy nearly the complete demand for welding of rails for the European networks.

A third process available for welding operations is Gas Pressure Welding (GPW). This process has not gained acceptance in European markets but is successfully deployed in other countries, for example Japan, China or India.

Metal electric arc welding use heat generated by electric current across the gap between two conductors. A metal electrode is energy loaded with electric voltage and then brought close to rails segments, producing an arc of electric current between the two metal sides. High heat is generated by this electric arc, causing the two ends side of rail to be welded.

For any welding technologies, used technologies or even new technologies, the following aspects need to be taken into account:

- No additional costs for the new welding process compared to the standard process; which means:
  - execution of the weld in a minimum of time without compromising accuracy and quality;
  - avoiding additional process steps during welding or any additional post weld treatments;
  - no usage of additional equipment;
  - avoiding the use of processes that make additional manpower necessary;
- If additional costs of the welding process are accepted, the additional expenses need to be compared with the resulting benefit. This means that it needs to be evaluated:
  - The lifetime of the weld should be increased;
  - The failure rate and maintenance requirements should be decreased;
- The applied welding technology should be as flexible as possible with regard to rail profiles, rail grades and rail condition (new or used rails);
- The applied welding technique should result in a weld with optimized properties with respect to: wear; resistance against rolling contact fatigue (RCF); minimum width of the heat affected zone (HAZ);
- The process should be as mobile and as easy to handle as possible;
- A further requirement for the development or improvement of current welding processes is their ability to weld premium grade steels in which property improvements have been achieved through alloying additions and/or heat treatment.

There are three preconditions that must be fulfilled if the presented improvements are to be realised:

- A good quality track with appropriate support;
- Sufficient time for the execution of a good quality weld in track;
- A comprehensive training and testing programme to ensure the competence and skills of the welders.

### 1.8.3.1 Flash Butt Welding

The fatigue strength of factory flash butt welds is very similar to that of plain rail and the solid phase welding process imparts high internal integrity. The resulting robust quality of this welding process is reflected in the almost complete absence of any failures in track. The two key modes of degradation associated with flash butt welds are:

- Weld “cupping” – differential wear across the Heat Affected Zone (HAZ);
- Weld “dipping” – loss of longitudinal alignment over a short distance but extending beyond the weld.

In flash butt welding, heat is generated by the electric resistance method. The ends of the two rails to be welded are firmly clamped into the jaws of a welding machine. One of the jaws is stationary, while the other is moveable and as such the gap between the two rails ends can be adjusted. It is not necessary to specially prepare the rail ends, though these can be preheated with an oxy-acetylene torch, if necessary. The rail ends are brought so close together that they almost touch each other. An electric current is passed between the interfaces of the two rails. The rails are subjected to a predetermined number of preheats e.g. 15 for 54 kg rails, before they are welded. Considerable heat is generated by the passage of electrical current between the rail ends. When the temperature rises to a fusion limit in the range of 1000°C to 1500°C, the rail ends are pressed together with an upset pressure of tens of tones and final flashing takes place joining the two rail ends together.

Flash butt welding machines are equipped with data logging equipment that monitor the key aspects of the process. Although audible alarms to indicate deviation from predetermined values of key parameters are available on some units, the analysis of the logged data is often restricted to visual assessment of the welding current and displacement charts.

The cost of a welded joint using this flash butt method is also quite low compared to other methods of welding. The method can be adopted most economically and efficiently into a workshop, for which capital investment is required.

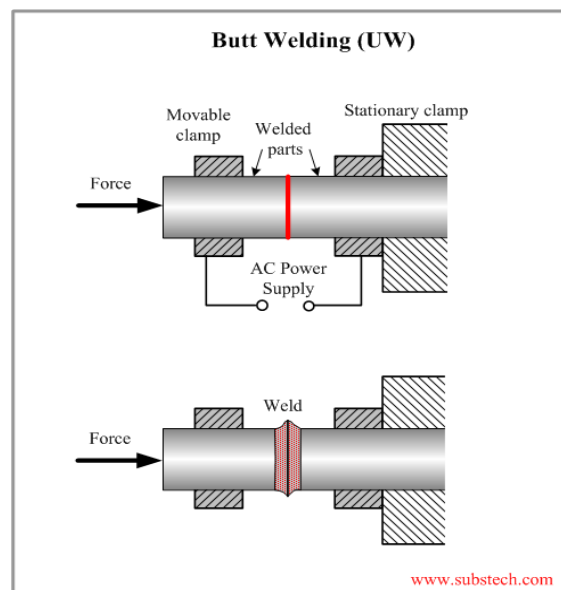

Figure 1.27 – Flush Butt Welding Technology<sup>20</sup>

Steps considered for good practice of the flash butt welding of rails:

- The rails are straightened before they are welded in order to ensure that the welded rail has a good alignment.
- The ends of the rails are cleaned for a length of 150-225 mm using electric or pneumatic grinders.
- The rail ends are then brought together in the flash butt welding machine and aligned longitudinally and vertically by suitably adjusting the machine.
- The rail ends are then welded in the flash butt welding machine.
- As soon as the rails are welded, they are made to pass through a stripping machine, where all the extra metal, called upset metal, is chipped off.
- In case there is no stripping machine available, the extra material on the rail head is chipped off manually using pneumatic chisels while the metal is still hot.
- The rails are cooled by spray cooling, after the hot metal is chipped off.
- The rails should be correctly profiled.
- The rails are straightened in the post straightening machine, to ensure perfect alignment in both directions.
- The rails as well as the welds are examined as ultrasonic inspection to ensure that there are no flaws in them; this step is most important for second-hand rails.
- The rail ends are finally examined and inspected with regard to specified tolerances so that the welded surface has a good finish.

The InnoTrack project has studied development of a narrow HAZ flash butt welding process that is covered by a Corus patent.

#### Development of narrow HAZ flash butt welds

---

<sup>20</sup> www.substech.com

A two-fold approach was adapted to achieve the desired aim of producing a factory flash butt weld with an HAZ width significantly narrower than those of standard production welds.

- As low a heat input as possible to achieve adequate weld consolidation.
- As low a conduction of heat away from the weld interface into the body of the rail as possible.

The achievement of the above objectives required close examination of the standard welding parameters and lead to the following key changes to arrive at a narrow HAZ weld:

- A slightly longer initial flash duration giving a longer localised heating cycle.
- A considerably lower number of preheats aimed at reducing the total heat input.
- Significant reduction in the durations of the preheat “on” and “off” periods aimed at reducing both the overall heat input and the total time for the heat to be conducted away from the weld interface.
- A shorter final flash duration giving a shorter localised heating cycle and reducing both the heat input and the heat conduction time.
- Lower forging (upset) distances – this is a direct consequence of the significantly reduced heat input levels.

#### **Weld properties of narrow HAZ (Heat Affected Zone) flash butt welds:**

- The bend test loads of the welds produced by the new process were similar to those observed in welds made using the standards process but with greater deflections;
- The width of the Heat Affected Zone (HAZ) has been significantly reduced;
- The hardness profile across the HAZ is more consistent and imparts wear resistance similar to the parent rails;
- Fatigue strength of the narrow HAZ welds is slightly better than that of standard flash butt weld;

#### **Key advantages of narrow HAZ flash butt welds:**

- The process results in a narrower heat affected zone with a consistent hardness profile that provides uniformity of wear resistance;
- The principles of controlled heat input employed in the process make it more suitable for the welding of premium grade steels produced either by micro alloying and/or heat treatment without the need for post weld controlled cooling.
- The shorter weld cycle times lead to greater productivity at the welding plant.
- The control of heat input results in an appreciable energy saving for the welding plant together with reduced wear and tear of the equipment.

#### **Flush Butt Welding of second-hand rails**

Second-hand rails can be welded conveniently in flash butt welding depots after being cropped for use on branch lines. European countries implement the welding of second-hand rails on a large scale in order to economize. The aspects that require particular attention in the welding of second-hand rails are as follows: checking of the dimensions of old rails as per specifications; matching the old rails; sawing the rail ends; planning the rail head; permissible wear of the rails to be welded; marking the gauge side; ultrasonic inspection of the rails.

### 1.8.3.2 Gas Pressure Welding

Gas pressure welding is a solid phase welding process that is used widely in Japan but has not yet gained acceptance in Europe. This welding process could be used in track in a similar way to that of mobile flash butt welding. The basic difference between the two processes is the method of heating of the rails.

In this type of welding, the necessary heat is produced by the combination of oxygen and acetylene gases. The rail ends to be welded are brought together and heat is applied through a burner connected to oxygen and acetylene cylinders by means of regulators and tubes. A temperature of about 1200°C is provided; the metal of the rail ends melts, resulting the fusion and welding together of the ends. The rails to be welded are butted with a pressure of about 20 tones. Then the joint is again heated to a temperature of 850°C and allowed to cool naturally.

The welding equipment and the welding process still need to be optimized in order to achieve a welding process that is comparable with (mobile) flash butt welding. The gas pressure welds presented in the InnoTrack reports did not fully meet the requirements for flash butt welds, particularly with reference to HAZ width and weld geometry. But, the results achieved indicate that gas pressure welding has the potential to become a reliable welding process. Although, gas pressure welds show a wider HAZ than flash butt and aluminothermic weld, the wear resistance of the HAZ region was found to be similar to that of parent R260 grade rail. However, the applicability of this process for welding of harder heat treated grades has to be researched in view of the wider HAZ.

The welding process and the equipment need to be optimized following which process approval to the requirements of a European standard (comparable to that of mobile flash butt welding, EN 14587-2) needs to be undertaken.

It has been seen that this method of welding is cheaper as compared to flash butt welding. The quality of this welding joint is also claimed to be quite good. There are both stationary and mobile units available for gas pressure welding.

### 1.8.3.3 Thermite Welding of Rails

Thermite welding of rails is the only form of site welding that is adopted universally. The method was first developed by Gold Schmidt of Germany towards the end of the nineteenth century.

Up to now no clear evidence is given regarding how long an aluminothermic (AT) weld can actually last within the track. The experience has shown that usually the weld lasts as long as the rail. Naturally, the traffic conditions, the condition of the superstructure and the maintenance of the track have influences in the life of at welds.

#### General Principles

The process principle: a mixture of aluminium and iron oxide, is ignited, a chemical reaction takes place which results in the evolution of heat and the production of iron and aluminium oxide:





The mixture is called thermite mixture. The reaction is exothermic and it takes about 15-25 seconds to achieve a temperature of about 2450°C. The released iron is in the molten state and welds the rail ends, which are kept enveloped in molten boxes. The aluminium oxide, being lighter, floats on top and forms the slag. (9)

### Different Types of Thermite Welding

These are conventional welding and SKV welding. SKV is the short form of the German phrase “Schweiss-Verfahren mit Kurz vorwärmung” meaning the short preheat welding method. The technique is therefore also termed SPW (short preheat welding).

The thermite process is a very convenient form of welding when work needs to be carried out at the site. No extra power is required and there is enough heat generated during the chemical reaction. The welded joint, however, is found to be weak in strength as compared to the flash butt welded joint.

The minimum hardness reached in the HAZ is basically determined by the chemical composition of the rail steel. The width of the HAZ of aluminothermic welds can only be influenced to a small extent. Here the duration of the pre-heating mainly determines the influence of the welding process on the width of the HAZ.

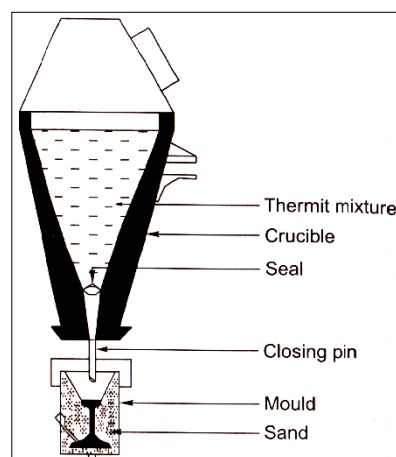

Figure 1.28 - Thermite welding equipment (synthetized)

### Width of the heat affected zone (HAZ) of an aluminothermic weld

One of the fundamental aspects that need to be considered with respect to in-service performance of at welds is the characteristics of the HAZ. During welding the rail steel adjacent to the weld metal is subjected to very high temperatures resulting in a well-known drop of hardness in the HAZ.

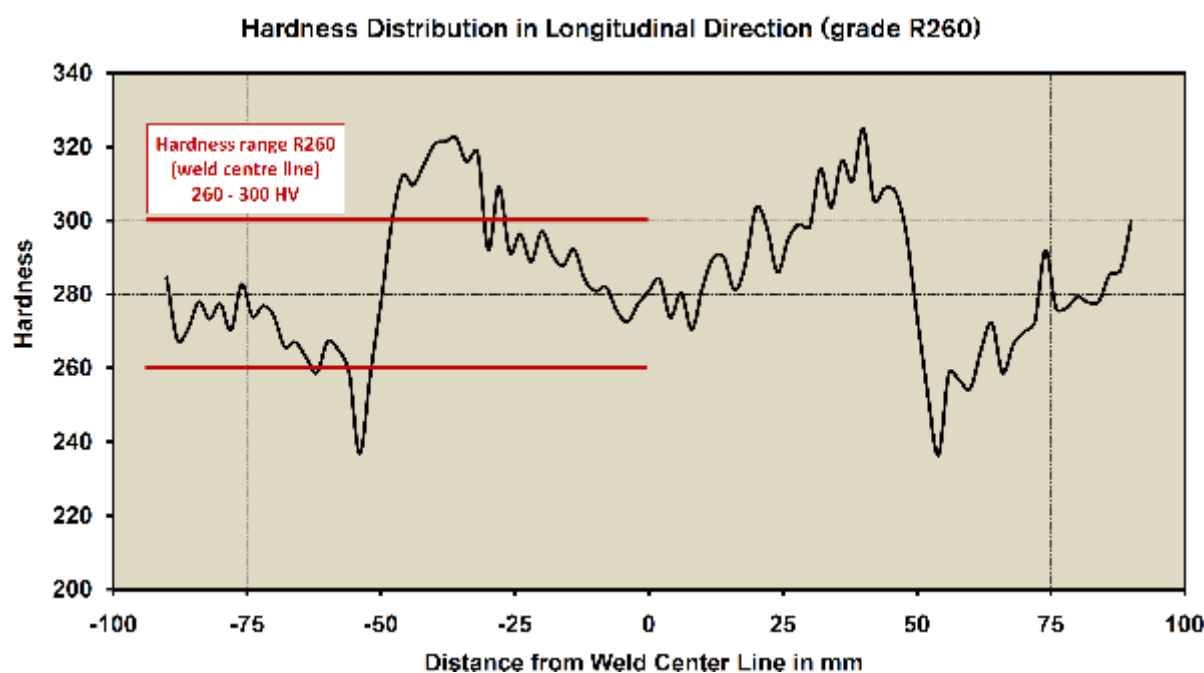

Figure 1.29 - Changing hardness of HAZ for R260 grade

### Short Preheat Thermite Welding Technique

With this technique, it is possible to reduce the total time taken for welding and chipping by about 30 minutes.

The main feature of this technique is that only a length of 3-5 mm at each end of the rails to be welded is heated to a temperature of 6000°C, as against the heating of the entire cross section of the rail to 1000°C, over a length of 10 - 15 mm in the conventional method of thermite welding. The large quantity of heat necessary for heating the rail ends is supplied by the use of a large quantity of thermite mixture.

Item/characteristic	Conventional aluminothermic welding	Short preheat thermite welding (SKV)
Weight of the thermite mixture	7 kg	10.5-13 kg
Preheating time with petrol and air	45 min.	10-12 min.
Total time taken from mould assembly to final chipping	60-65 min.	20-30 min.
Initial gap between rail ends	12-14mm	23-25 mm
Preheating technique	Side heating	Top heating
Type of moulds	Green sand mould.	Prefabricated mould.
Petrol consumption	3.41	1.01

Table 1.2 - Important features of conventional and SKV welding (9)

### Precautions during Thermite Welding:

- All the relating equipment and gadgets should be verified and available at the site.
- Thermite welding of joints should be carried out strictly as per the prescribed norms. In particular, care should be taken to see that the rail ends are square and that their alignment is perfect.
- Thermite welding should be done only by qualified welder persons with a valid competency certificate.
- Thermite welding should be done only under the supervision of a qualified permanent inspector with valid competency certificate.
- Second-hand rails should not be welded before their ends have been cropped. The rail ends should be cropped vertically and thoroughly cleaned with kerosene oil with the help of a brush.
- In order to get good results, proper gaps should be ensured between the two rails to be welded. The standard gaps recommended are the following:
  - Conventional welding  $11 \pm 1$  mm
  - SPW or SKV welding  $24 \pm 1$  mm
- A rail tensor must be used for maintaining the correct gap when thermite welding rails in a decreasing range of temperature and also when repair welding on LWR/CWR (long welded rail/continuous welded rail) tracks. In the case of repair welding, at least 100 m on either side of the weld should be de-stressed in order to get good results.
- In the field, thermite welding should be done on the cess as far as possible to ensure the quality of the welded joints.
- The segments of the rail have to be welded should be kept on wooden planks to ensure that moisture does not enter these portions.

Up to now no study has been undertaken systematically evaluate the influence of the HAZ width (and rail profile and rail grade) on the track/rail/weld performance (wear, RCF and failure mechanisms). The interaction between rail (and weld) and wheel are more dependent on axle load, speed of the wheel and the friction between rail and wheel. Thus a large matrix of possible test conditions can be created. A detailed evaluation of the performance of the HAZ in comparison to the unaffected rail steel or weld metal should be the scope of future investigations, especially with new rail grades aiming for higher hardness and thus making the HAZ eventually more critical for the failure mechanisms mentioned.

Description of item	Flash butt welding	Thermite welding
Principles of welding	By passing a 35 kA electric current between two rail ends	By initiating an exothermic chemical reaction between iron oxide and aluminium.
Quality of welding	Excellent	Good
Strength of welding	Good in fatigue	Weak in fatigue
Time required for welding	About 3-6 min.	10-12 min. for SKV and 30-45 min. for conventional

Place of welding	Normally in workshop	On site
Tolerance	Very high	Normal
Control on the quality of welding	Quality can be controlled with the help of a welding recorder	Quality control is possible only by working carefully and no monitoring is possible

**Table 1.3 - Comparison of flash butt and thermite welding**

### Post weld treatments

It is generally possible to achieve improved properties in an aluminothermic weld and the adjacent HAZ by additional treatment of the weld after the welding process.

Two methods have been introduced within the InnoTrack project: a mechanical post weld treatment (UIT method – Ultrasonic Impact Treatment) and a thermal treatment executed after the welding process. The first method focussed on a mechanical treatment of the weld collar of the finished weld in order to improve the fatigue properties. The second method was applied to change the microstructure and to soften the base and web of the finished weld in order to increase the properties (deflection) during the static bend test.

Beside the thermal treatment mentioned above, another heat treatment can be executed in order to modify the weld properties. This so-called HC-treatment causes the formation of a very fine pearlitic microstructure and an increase of hardness. This second heat treatment covers the HAZ that has been created by the initial welding process. A new, small HAZ will be formed at the borders from the area that is affected by the post heat treatment. This process requires additional pre-heating equipment and it needs to be executed on the finished rail after fine grinding.

There are also other methods available – mechanical as well as thermal treatments that can be applied to the weld. However, none of these processes have gained acceptance as standard processes to be used in track. The additional costs and the additional time required to execute the post weld treatment are the most relevant reasons why these methods are not used.

For certain track conditions, e.g. heavy haul lines, special post treatments might be beneficial (UIT - treatment) if fatigue life is the limiting factor. This is not the case for European mixed or high-speed traffic. However, these methods need to be homologated and find acceptance by the railway authorities before operational usage.

#### 1.8.3.4 Modern Technologies used in welding rails

For head hardened rails, an innovation in aluminothermic welding is when a selective alloying system results in the head of the weld gets a high hardness whereas the web and the foot remain soft. This is a hardness distribution comparable to that of the bulk material of the head hardened rail. This welding principle leads to improved fatigue properties of the weld due to a higher ductility in the rail foot, and higher fracture toughness in the railhead. This method can also be used for welding standard rail grades and also, reduces logistical effort (lower costs) regarding the handling and provision of consumables. However, the promotion of this process is currently focused on heavy haul tracks but, as yet, its use has been very limited. Within the InnoTrack project this new welding process and its applicability in track were studied in detail during a track test.

The using of a performant welding recorder for controlling the quality of welding in the flash butt welding method is a step away for welding improvements quality. The recorder is able to not only identify the defects in the flash butt welded joint, but also indicate the reasons for the same. A very sophisticated recording system has recently been developed on the German Railways with the help of Siemens. This system gives visible and audible indications whenever any parameter controlling the quality of the weld transgresses the predetermined limits. The recorder helps considerably in exercising proper control on the quality of welding.

A new method of thermite welding rails that does not involve preheating is currently being tested on German Railways. The necessary heat is produced by much larger quantities of a specially-manufactured aluminium - thermite mixture. This method also involves the use of special prefabricated mould made from pure quartz sand. This method of welding requires considerably less amount of time due to the prior solidification of the material in the mold.

Large gap welding technique – in general, the fractured rail welds have to be replaced by a long rail closure. This rail piece is inserted in the track after creating a gap of about the same length and welded with the existing rail on both the ends. Thus, in order to remove one defective/fractured aluminium thermite (AT) weld, two AT welds are created. The whole process of replacing the fractured/defective weld with closure rail piece involves considerable amount of manpower and block time as well as wastage of rails. With the development of 75-mm wide gap welding technique, the defective/fractured weld can be replaced with a single manpower and block time required for the execution of AT welds also reduces considerably. The major procedural difference between the standard 25 mm gap welding and 50/75 mm wide gap welding arise mainly due to larger quantity of thermic steel the latter in due to increased volume and solidification. Hence, this results in temperature dependent this results in post welding activities. The time required for the executing of wide gap welding joint is slightly longer than a standard 25 mm weld, but still lower than the time required for two 25 mm standard welds.

Both systems of welding mainly used in Europe (aluminothermic welding and flash butt welding) have advantages and disadvantages. The aluminothermic welding technique is very mobile and requires less specialised equipment and is therefore suitable for the repair and maintenance purposes and can be used for not only for the joining of rails but also for the repair of squats and other rail defects. The aluminothermic welding kit consists of aluminium and iron oxide powders which upon contact with each other produce an exothermic reaction as the aluminium bonds with the oxygen ions and the iron oxide is reduced to iron. The aluminothermic welds therefore have different material properties to the rail and can become a source of failure due to fatigue cracking.

Flash butt welding requires the two ends of the rail to be butted up against each other and very high electrical currents are passed across the joint creating heat and the fusing of the two rail ends. Flash but welding requires specialist equipment, but as no additional material is added to the rails the material properties are more similar to that of the rail, with small variations in hardness in the heat affected zone (HAZ) either side of the join. Flash butt welding is carried out in the manufacture of

long rail steel lengths in the factory and also mobile flash butt welding equipment is now commonly used for new installations and renewals, but less so for repair and maintenance purposes.<sup>21</sup>

## 1.9 Long-welded rail (LWR)

As generally consideration a rail with a length greater than 250 m have to be considered as an LWR (Figure 1.30). This category of welded rail has characteristics that the central portion does not achieve any thermal expansion (longitudinal contraction or expansion due to temperature variation).

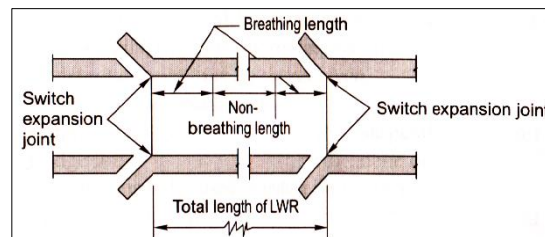

Figure 1.30 - Long-welded rail

Modern railways use long welded rail lengths to provide a better ride, reduce wear, reduce damage to trains and eliminate the noise associated with rail joints.

Development of railways with welded rails was done because economic consideration, coupled with the technical advantages. Rails were originally welded panels of three, five, ten, etc. standard lengths of rail. The development of these panels railway was the first step in developing the tracks in most rail network

Considerable progress has been made in the area of railway technology, in the course of time, and a new rail concept of "blocking up of stresses tension" was developed; it is the ability to withstand any changes in the length of the rail. Consequently, rails welded to large lengths up to 1 km, were made to eliminate any rail joints as rails connection. The concept of continuous welded rails is now developing rapidly and welded rails are being laid continuously on long distances.

When the rails are fastened to the sleepers and sleepers are incorporated into the ballast, the expansion and contraction of the rail, related to temperature changes, are restricted. This restriction gives rise to internal tensions, blocked the railway metal, these are known as thermal power.

### 1.9.1 Longitudinal Thermal Expansion of LWR and Breathing Length

The thermal expansion of the rail takes place at the ends of the rail, due temperature variations. An LWR continues to expand at its ends up to that particular length at which an resisting force is developed as opposite, towards the centre. An equilibrium is reached at a particular length of the rail when the resistance of the track structure become equal to the thermal forces. This alteration in length is limited to a portion at the ends of the LWR. The central portion of the LWR, where the force is constant, is stable and does not any change in its length. The segment at the end of rail affected by the thermal expansion is named the breathing length.

<sup>21</sup> InnoTrack Concluding Technical Report section 5.6, UIC, 2010 <http://innotrack.eu>

### **1.9.2 Prohibited Locations of LWR**

Long welded rails are not recommended to be used on the following situations:

- The formation and the track are not fully stabilized; in these situations mechanical compaction of the earthwork should be done.
- Track rails are affected by heavy wear, corrugation, or corrosion, or require frequent renewal.
- Buckling of rails when the formation is weak and track deformations are excessive.
- Flooding events or frequent rail breaches.

The minimum length needed for a railroad to operate as an LWR depends by: the ranges of temperature in that region, the ballast resistance opposite to the thermal expansion of beams, and the resistance offered by rail assembly. Normally, a track length of 100 m is subjected to thermal expansion at each end of the rail. Generally a length exceeding 250 m, as welded rail segment, could be considered LWR.

Where the formation is bad, it should be stabilized before the LWRs are laid. The formation should not pose any problems in the laying of LWRs. In the case of concrete sleeper tracks, an extra cess width is provided to the extent of embankments and for cuttings. For this is helping if clean ballast cushion it is provided below the bottom of the sleeper for LWRs.

Sleepers prescribed for LWR and also CWR (Continuous Welded Rails): concrete sleepers with elastic fastening; durable hardwood sleepers.

Particularly considerations for maintenance of LWR: the track should be left undisturbed as far as possible and only essential track maintenance work should be carried out at temperatures close to the de-stressing temperature; the track should preferably be maintained mechanically with tamping machines; well-compacted ballast bed should be available below the sleepers at all times to give adequate lateral and longitudinal resistance to the track in order to prevent buckling and excessive alterations in the sleeper lengths of the LWR track;

### **1.9.3 Switch Expansion Joint**

The switch expansion joint is a device installed at the end of LWRs to allow the thermal expansion of the breathing length.



Figure 1.31 - An expansion joint on the Cornish Main Line, England



Figure 1.32 - Switch Expansion Joint <sup>22</sup>

#### 1.9.4 De-stressing of LWR

De-stressing is the process of relieving the stresses in a long welded rail which are set up due to change in the temperature.

De-stressing is necessary if one of the next situations:

- Gap at SEJ (switch expansion joint) differs from limits specified or exceeds the maximum designed gap for SEJ.
- After special maintenance operations as deep screening, lifting or lowering of track, major realignment of curves, sleeper renewals, other renewals and rehabilitation cases (e.g. for bridges and formation) causing disturbance to track.
- After radical maintenance related to rail fractures or replacement of defective rail, damage of SEJ, buckling and breaches of rails, etc.
- If number of locations where temporary repairs have been done exceeds 3 per km.

---

<sup>22</sup> (Source: [iricen.indianrailways.gov.in](http://iricen.indianrailways.gov.in))



### **1.9.5 Continuous Welded Rails**

The length of LWR has been limited to about 1 km; welded panels longer than 1 km are known as continuous welded rails. On this technology, rails are welded continuously, from station to station. Exceptions are turnouts with switch and crossings which are isolated using switch expansion joints.

The theory for continuous welded rails is the same as for LWR. The concept of locking up of longitudinal thermal forces permits to extend welding rails beyond the length of LWR (about 1 km). The switch expansion joints or buffer joints that are provided at the ends of LWR are considered also as a source of weakness in the track, requiring heavy maintenance; CWR have to avoid this situation, were laid from station to station. In fact, on European Railways, particularly on German and British Railways, LWR or continuous welded rails have been laid for several miles which pass through stations, yards, etc., without inclusion of any SEJ.

LWRs and CWRs are part of modern high-speed tracks and require very little maintenance as compared to fish-plated tracks.

### **1.9.6 Buckling of Track**

When the compressive forces in the track exceed the lateral or longitudinal resistance of the track, a rail track could be deformed; this phenomena is happened particularly in hot weather and is named buckling of the track. When buckling of the track reach visible level, is a matter of concern as it may lead to derailments and serious accidents.

Symptoms of buckling of track: expansion/contraction at Switch Expansion Joint (SEJ) more than the theoretical range given in the LWR documentation; presence of kinks in the track; absence of gaps in the breathing portion of the track when temperature is rising.

Causes of buckling of track: deficiencies in the ballast which lead to low resistance of track; low efficiency for fastenings, low quality of welding track lead to sunken portions in a welded track, laying, de-stressing, maintaining, or raising the track outside the specified temperature range (e.g. hot weather); deficient lubrication of the Switch Expansion Joint (SEJ); jammed joints, etc.

Preventive measures to avoid buckling: proper expansion gaps; no work of track maintenance will be done outside the specified temperature; wherever the track structure is weak and vulnerable to buckling, action should be taken to strengthen the provision of extra shoulder ballast, to increase in sleeper density, replacement and tightening of missing and loose fastenings, etc.

One of the methods to reduce buckling effect, especially for large surface of metal exposed, is painting crossings surface to white, to reduce solar buckling.

When buckling takes place, traffic on the affected track should be suspended and remedial work should be carried out as for examples: the temperature of the rail should be brought down as far as possible; emergency or permanent repairs and de-stressing should be carried as specified, etc.

## **1.10 Gauge**

In rail transport, track gauge is the spacing of the rails on a railway track and is measured between the inner faces of the load-bearing rails. All vehicles on a rail transport network must have running

gear that is compatible with the track gauge and this is the dominant parameter determining interoperability.

A "structure gauge" is needed to ensure that the path required for the passage of trains is kept clear along the route of a railway having as effect of forming a limit of building inside which no structures may intrude. The limit includes walls, bridges and columns pipes, cables, brackets and signal posts. The "structure gauge" will vary with the curvature of the line and the maximum speeds allowed.

The civil engineer had to allow his structure to intrude into the train path and the rolling stock engineer has limits imposed on the space his train may occupy. This space is referred to as the "kinematic envelope". This area designates the limits the train can move laterally and vertically along the route. The structure gauge and also the kinematic envelope will be affected by speed and features of train design such as the bogie suspension and special systems it may have like tilting.

There is a distinction between the nominal gauge and actual gauge at some locality, due to divergence of track components from the nominal. Railway engineers use a device to measure the actual gauge referred to as a track gauge.

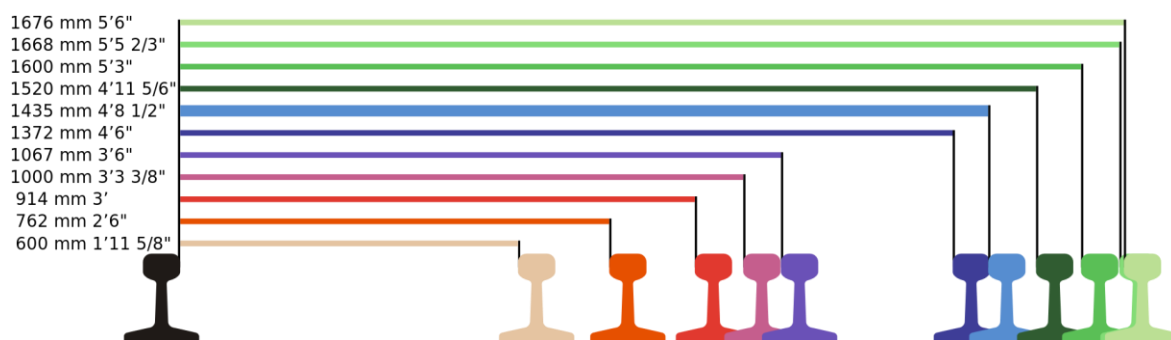

Figure 1.33 Track gauge dimensions

The nominal track gauge is the distance between the inner faces of the rails. In current practice it is specified at a certain distance below the rail head as the inner faces of the rail head (the gauge faces) are not necessarily vertical. Rolling stock on the network must have running that are compatible with the gauge. The wagons might be referred to as "four-foot gauge wagons", say, if the track had a gauge of four feet. The standard track gauge - the distance between the two rails - is 4 ft. 8½ in or 1435 mm. but many others gauges, wider and narrower than this, are in use around the world (see Figure 1.33).

The line of route has to be checked from time to time to ensure that the structures are not interfering with the gauge. A line is always gauged when a new type of rolling stock is to be introduced. It is important to see that the small variations in track position, platform edge, and cable duct location and signal equipment hasn't been allowed to creep inwards during maintenance and renewal programs.

Gauging used to be done by hand locally (and still is from time to time in special circumstances) but it is mostly done with a special train. The train used consists of a special car with a wooden frame built almost to the gauge limits. The edges of the frame were fitted with lead fingers so that, if they hit anything as the train moved along, they would bend to indicate the location and depth of intrusion.

Modern gauging trains are fitted with optical or laser equipment. The optical system uses lights to spread beams of light out from the train as it runs along the line. Suitably mounted cameras record the breaks in the light beams to provide the gauging information. The train can run at up to 50 mi/h (80 km/h) but, of course, the runs have to be done at night. Laser beams are also used but, as they rotate round the train and form a "spiral" of light, the method suffers from gaps which can allow intrusions to be missed.

### 1.11 Switch and Crossings

Switch (also named points) and crossings are provided to help transfer railway vehicles from one track to another. The tracks may be parallel to, diverging from, or converging with each other. Points and crossings are necessary because the wheels of railway vehicles are provided with inside flanges and, therefore, they require this special arrangement in order to going their way on the rails. The points or switches aid in diverting the vehicles and the crossings provide gaps in the rails so as to help the flanged wheels to roll over them. A complete set of points and crossings, along with lead rails, is called a turnout.

The following terms are often used in the design of points and crossings:

**Turnout** - It is an arrangement of points and crossings with lead rails by means of which the rolling stock may be diverted from one track to another.

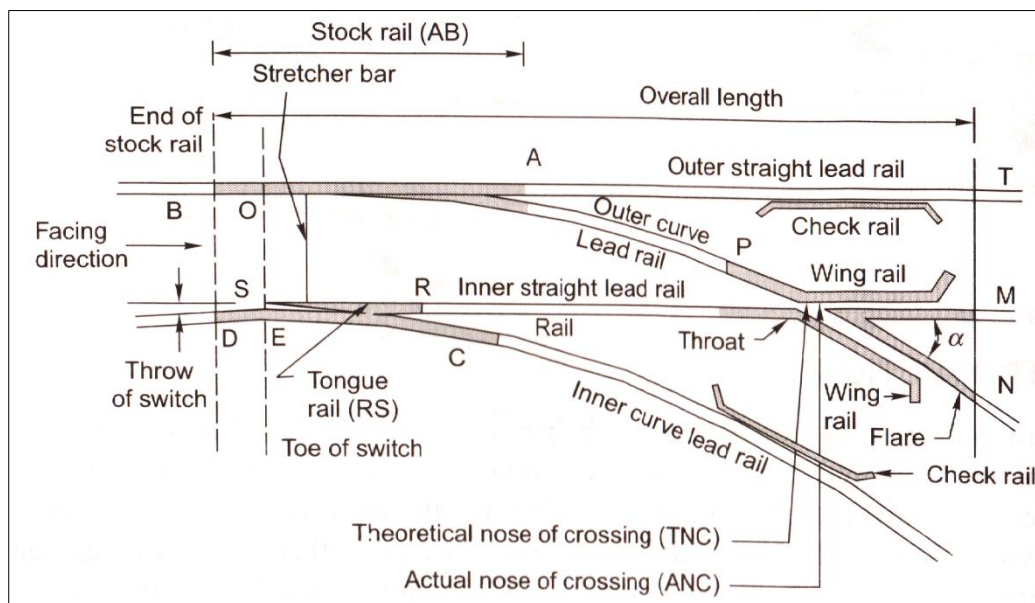

Figure 1.34 - Constituents of a turnout (right hand turnout)

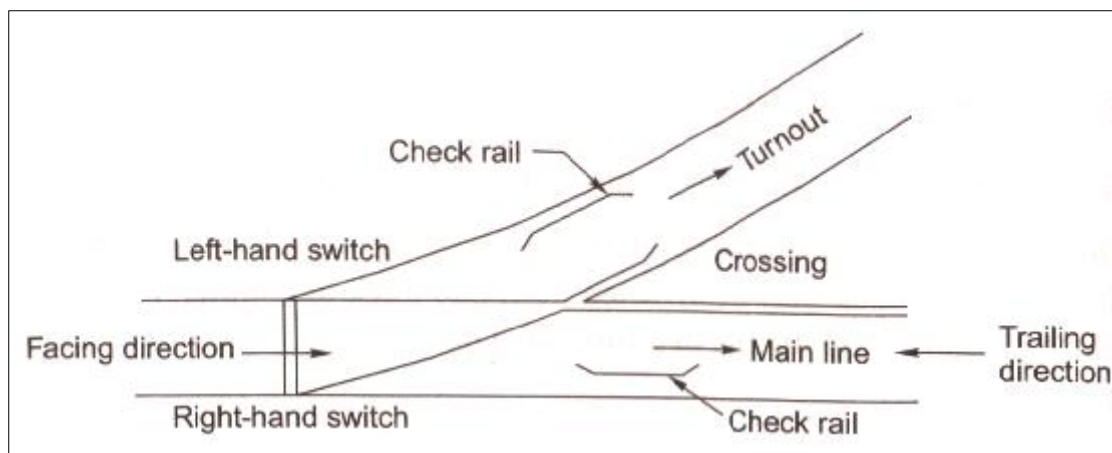

Figure 1.35 - Left-hand turnout

Components of a turnout are following:

- Set of switches: a pair of stock rails, a pair of tongue rails, a pair of heel blocks, several slide chairs, two or more stretcher bars, and a gauge tie plate;
- Crossing: a nose consisting of a point rail and splice rails, two wing rails, and two check rails;
- Lead rails: four sets of lead rails.

**Direction of a turnout.** A turnout is designated as a right-hand or a left-hand turnout, depending on whether it diverts the traffic to the right or to the left. The direction of a point (or turnout) is known as the facing direction if a vehicle approaching the turnout or a point has to first face the thin end of the switch. The direction is trailing direction if the vehicle has to negotiate a switch in the trailing direction, that is, the vehicle first negotiates the crossing and then finally traverses on the switch from its thick end to its thin end. Therefore, when standing at the toe of a switch, if one looks in the direction of the crossing, it is called the facing direction and the opposite direction is called the trailing direction.

**Tongue rail.** It is a conical movable rail, made of high-carbon or manganese steel to withstand wear. At its thicker end, it is attached to a running rail. A tongue rail is also called a switch rail.

**Stock rail.** It is the running rail against which a tongue rail operates.

**Switch or points.** A pair of tongue and stock rails with the necessary connections and fittings forms a switch.

**Crossing.** It is a device introduced at the junction where two rails cross each other to permit the wheel flange of a railway vehicle to pass from one track to another.

### 1.11.1 Switches

A set of switches consists of the following main constituents (see Figure 1.36).

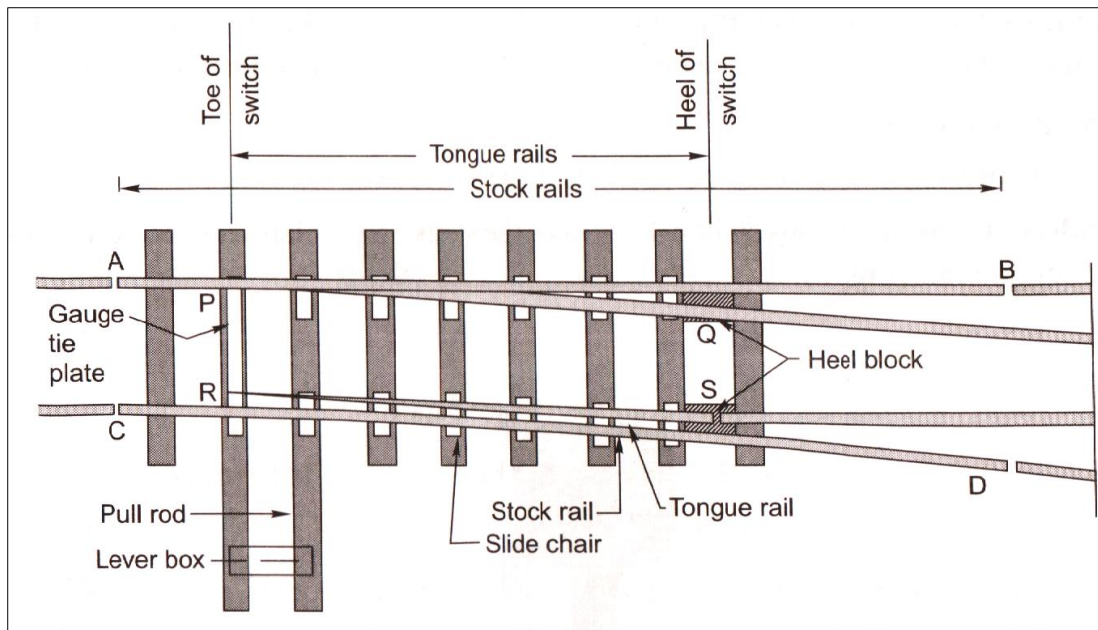

Figure 1.36 - Details of a switch

- A pair of stock rails, AB and CD, made of medium-manganese steel.
- A pair of tongue rails, PQ and RS, also known as switch rails, made of medium-manganese steel to withstand wear. The tongue rails are machined to a very thin section to obtain a snug fit with the stock rail. The tapered end of the tongue rail is called the toe and the thicker end is called the heel.
- A pair of heel blocks which hold the heel of the tongue rails is held at the standard clearance or distance from the stock rails.
- A number of slide chairs to support the tongue rail and enable its movement towards or away from the stock rail.
- Two or more stretcher bars connecting both the tongue rails close to the toe, for the purpose of holding them at a fixed distance from each other.
- A gauge tie plate to fix gauges and ensure correct gauge at the points.

**Types of Switches.** Switches are of two types, namely stud switch and split switch. In a stud type of switch, no separate tongue rail is provided and some portion of the track is moved from one side to the other side. Split switch consist of a pair of stock rails and a pair of tongue rails. Split switches may also be of two types-loose heel type and fixed heel type.

**Loose heel type.** In this type of split switch, the switch or tongue rail finishes at the heel of the switch to enable movement of the free end of the tongue rail. The fish plates holding the tongue rail may be straight or slightly bent. The tongue rail is fastened to the stock rail with the help of a fishing fit block and four bolts. All the fish bolts in the lead rail are tightened while those in the tongue rail are kept loose or snug to allow free movement of the tongue. As the discontinuity of the track at the heel is a weakness in the structure, the use of these switches is not preferred.

**Fixed heel type.** In this type of split switch, the tongue rail does not end at the heel of the switch, but extends further and is rigidly connected. The movement at the toe of the switch is made possible on account of the flexibility of the tongue rail.

**Toe of switches** - The toe of the switches may be of the following types.

- **Undercut switch.** In this switch the foot of the stock rail is planned to accommodate the tongue rail.

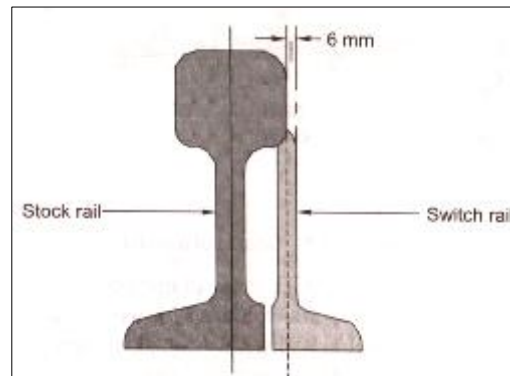

Figure 1.37 - Undercut switch

**Overriding switch.** In this case, the stock rail occupies the full section and the tongue rail is planned to a 6 mm (0.25")-thick edge, which overrides the foot of the stock rail. The switch rail is kept 6 mm (0.25") higher than the stock rail from the heel to the point towards the toe where the planning starts. This is done to eliminate the possibility of splitting caused by any false flange moving in the trailing direction. This design is considered to be an economical and superior design due to the following reasons:

- Since the stock rail is uncut, it is much stronger.
- Manufacturing work is confined only to the tongue rail, which is very economical.
- Although the tongue rail has a thin edge of only 6 mm (0.25 "), it is supported by the stock rail for the entire weakened portion of its length. As such, the combined strength of the rails between the sleepers is greater than that of the tongue rail alone in the undercut switch.

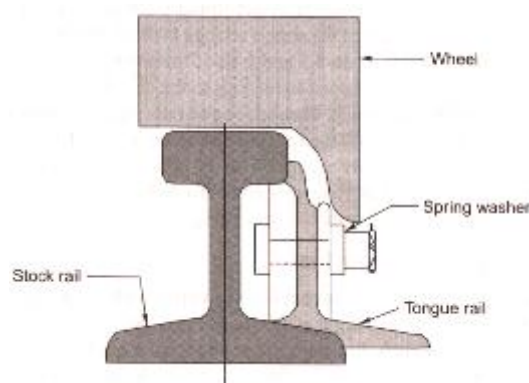

Figure 1.38 - Overriding switch

The following terms are common when discussing the design of switches.

**Switch angle** - angle between the gauge face of the stock rail and that of the tongue rail at the theoretical toe of the switch in its closed position. It is a function of the heel divergence and the length of the tongue rail.

**Flange way clearance** - distance between the adjoining faces of the running rail and the check rail / wing rail at the nose of the crossing.

**Heel divergence** - distance between the gauge faces of the stock rail and the tongue rail at the heel of the switch. It is made up of the flange way clearance and the width of the tongue rail head that lies at the heel.

A tongue rail may be either straight or curved:

- Straight tongue rails have the advantage that they are easily manufactured and can be used for right-hand as well as left-hand turnouts.
- Curved tongue rails are shaped according to the curvature of the turnout from the toe to the heel of the switch. Curved tongue rails allow for smooth turning of trains, but can only be used for the specific curvature for which they are designed.

The length of a tongue rail from heel to toe varies with the gauge and angle of the switch. Longer length of the tongue rail means smoother entry to the switch because of smaller angle that the switch rail would make with the fixed heel divergence; but the longer tongue rail occupies too much layout space in station yards where a number of turnouts have to be laid in limited space.

### 1.11.2 Crossings

A crossing, or frog, is a device introduced at the point where two gauge faces cross each other to permit the flanges of a railway vehicle to pass from one track to another (see Figure 1.39). To achieve this objective, a gap is provided from the throw to the nose of the crossing, over which the flanged wheel glides or jumps. In order to ensure that this flanged wheel negotiates the gap properly and does not strike the nose, the other wheel is guided with the help of check rails.



Figure 1.39 – Example of Crossings

A crossing consists of the following components, shown in Figure 1.40:

- Two rails, point rail and splice rail, which are machined to form a nose. The point rail ends at the nose, whereas the splice rail joins it a little behind the nose. Theoretically, the point rail should end in a point and be made as thin as possible, but such a knife edge of the point rail would break off under the movement of traffic. The point rail, therefore, has its fine end slightly cut off to form a blunt nose, with a thickness of 6 mm (1/4"). The toe of the blunt nose is called the actual nose of crossing (ANC) and the theoretical point where the gauge faces from both sides intersect is called the theoretical nose of crossing (TNC). The 'V' rail is planned to a depth of 6mm (1/4") at the nose and runs out in 89 mm to stop a wheel running in the facing direction from hitting the nose.

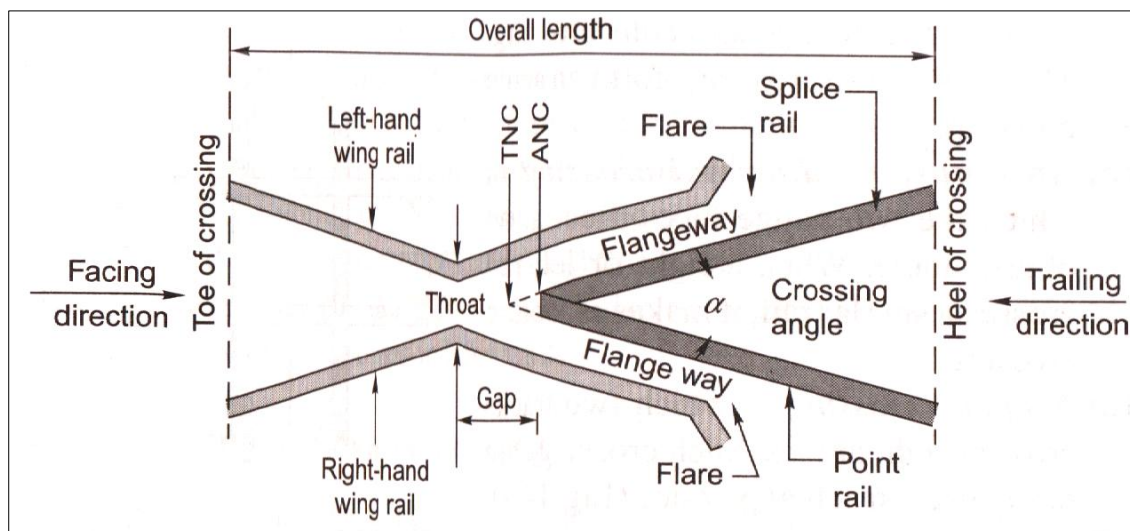

Figure 1.40 - Details of a crossing

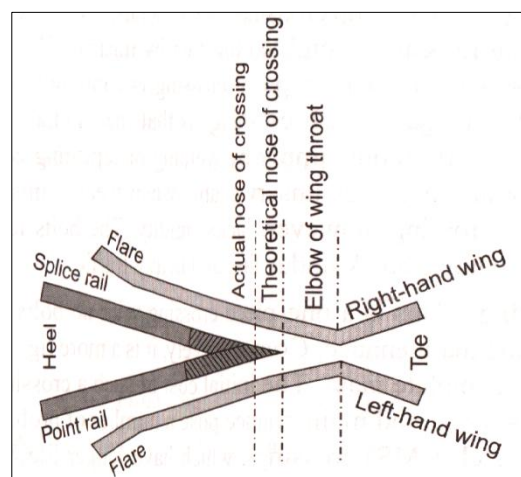

Figure 1.41 - Point rail and splice rail

- Two wing rails consisting of a right-hand and a left-hand wing rail that converge to form a throat and diverge again on either side of the nose. Wing rails have role to facilitate the entry and exit of the flanged wheel in the gap.



- A pair of check rails to guide the wheel flanges and provide a path for them, thereby preventing them from moving sideways, which would otherwise may result in the wheel hitting the nose of the crossing as it moves in the facing direction. (9)

Types of crossing are the following:

- An acute angle crossing or 'V' crossing in which the intersection of the two gauge faces forms an acute angle. For example, when a right rail crosses a left rail, it makes an acute crossing.
- An obtuse or diamond crossing in which the two gauge faces meet at an obtuse angle. When a right or left rail crosses a similar rail, it makes an obtuse crossing.
- A square crossing in which two tracks cross at right angles. Such crossings are rarely used in actual practice.

Other classification of crossings could be considered from manufacturing purposes point of view:

- **Built-up crossing** - in a built-up crossing, two wing rails and a V section consisting of splice and point rails are assembled together by means of bolts and distance blocks to form a crossing. The advantage of such crossings is that their initial cost is low and that repairs can be carried out simply by welding or replacing each constituent separately. A built-up crossing has no rigidity; the bolts require frequent checking and are happens to break under fast and heavy traffic.
- **Cast steel crossing** – it is a one-piece crossing with no bolts and, therefore, requiring very little maintenance. Comparatively, it is a more rigid crossing since it consists of one complete mass. The initial cost of such a crossing is high and its repair and maintenance pose a number of problems. Recently, cast manganese steel (CMS) crossings, which have longer life, have also been adopted.
- **Combined rail and cast crossing** – it is a combination of a built-up and cast steel crossing and consists of a cast steel nose finished to ordinary rail faces to form the two legs of the crossing. Though it allows the welding of worn-out wing rails, the nose is still liable to fracture suddenly.

## 2. Technologies for completely new installations, or significant rebuilding railway lines

---

### 2.1 General considerations

For completely new installations, or significant rebuilding, a wider range of technologies is within scope, including rail grade selection, crossing types, sleeper spacing, ballast and sub-structure, for which best practice for different line types will be documented. For both existing and new installations the survey will identify also good active and passive measures to enhance system life.

Necessity to construct new railway line arises from following considerations:

- Regions with low grade of economic and social development. Experience has shown that once railway connectivity is available, these regions will develop very fast.
- Trade Centres need to be connected. New trade centres for profitability should be connected by railway lines to get quick transportation of goods between them.
- Political and strategic reasons. Railway lines, sometimes, becomes necessary to serve the political needs of the country or to extend railway network to new points of strategic importance so that the national defence forces can move quickly to the areas, in case of any emergency.
- Routes between two important points may be longer than required; in this case are constructed new lines on a shorter alignment. A short route is economical but also helps in the faster movement of goods and passengers. Doubling of existing single railway lines is also an improvement to cover the additional requirement of traffic, for example to have a uniform gauge for the smooth flow of traffic.

Railway line as new constructions are capital-intensive investments and each kilometre of the new railway line has higher costs. These costs are depends by the topography of the area, by standard of construction, etc. A railway in operation is very difficult to be changed, principally as alignment line because of the structures involved, difficulty in getting additional land for the new alignment, and many other considerations.

For a new railway line construction should be considered preliminary investigations, by the railway administration to determine how the proposed line will fit in the general scheme of future railway development. The preliminary investigations are normally based on studies for followings:

- Newest topographic sheets and detailed maps of the area;
- Statistics of trade and population for the area to be served;
- Statistical data of existing railway lines in similar terrain in other areas;

#### 2.1.1 Standard elements should be considered for new construction:

- **Gauge.** This includes the gauge adopted for the proposed line and the reasons for adopting it.
- **Category of line.** This includes the category of the line, the loading standard of bridges and the maximum speed potential of the line, the maximum axle load.
- **Ruling gradient.** This includes the gradient adopted and the basis for its selection.
- **Curves.** This includes the sharpest degree of curvature adopted, the basis for its adoption, and its impact on the projected speed compatible to the category of line.

- **Permanent way.** This includes the rail section adopted, the decision as to whether welding of the rails will be carried out or not, and the type and density of sleepers provided in the project estimate.
- **Ballast.** This includes the type and depth of ballast cushion provided.
- **Stations.** This includes spacing of stations in the case of new lines, provision for future intermediate stations, and the facilities available at stations.
- **Signalling and telecommunication.** This includes the standard of signalling adopted and the communication facilities provided.
- **Traction.** This includes the type of traction proposed.
- **Other details.** This includes road crossings, station machinery, residential accommodation, service and maintenance facilities, etc.

Once a decision has been taken during preliminary investigations about the general feasibility and desirability of a railway line, preliminary survey should be undertaken before the construction of the new line. Depending by importance (economic, social, etc.) and dimension of the new railway and the investments volume, surveys could be done in multiply stages and categories of surveys.

As a result of these investigations, it becomes possible to decide whether or not the new railway line is necessary and surveys should then be undertaken to get more details of the new line being contemplated. Analyses related to traffic conditions should determine: most reliable and profitability route for the railway in the area; which possible traffic the new line could transport; standards of railway line to be followed. Survey related to traffic conditions are normally undertaken in conjunction with other types of engineering surveys so that the technical feasibility and relative costs of alternative proposals can be formulated. The survey team should visit all trade centres in the area and consult local bodies, state governments, and prominent citizens regarding trade and industry and propose the most suitable alignment for the new line. Traffic survey consists of an economic study of the area having in consideration the information have to be collected: planning for economic development of the area; human resources; agricultural and mineral resources; pattern of trade and commerce; industries that exists but also to be projected; statistics and expectation of tourist traffic; existing facilities for other type of transportation; locations of important government and private offices.

Other kind of survey are focused on investigation of the area with a view to determine the technical feasibility of the proposal as well as the rough cost of one or more alternatives to the new line. This reconnaissance survey (RECCE) is normally based on maps and other sources of data already available. Different alternative alignments of the new line are studied.

In last part of the surveying activities have to be proposed a selected solution and should be detailed information related to, in order to estimate the cost of the proposed railway line. Based on the all actual and previous information, the railway administration decides whether or not the proposed railway line is to be constructed.

### 2.1.2 Modern techniques for surveying activities

Satellite imageries as well as topographic maps are available for almost all places around the world. Modern survey technology uses satellite imageries, aerial photographs, and digital terrain modelling

to decide the initial alignment, the intermediate alignment solutions as well as final location of the new railway line. These are very useful in initial marking out of any new alignment of railway line. Satellite imageries can also help in generating topographical data of the route.

Subsequently, aerial photographs can be taken of the area and with the help of topographical sheets, satellite imageries, and aerial photographs, digital terrain models can be generated. These models will be able to help in further refining the alignment at the most optimal solution, which can meet all the requirements of the new line.

Once the desired alignment is checked out, field units can be go to get actual field data including hydrological and geological data for planning and execution of the project. Modern survey techniques can expedite the survey work and also, can reduce many from the expenses of the project.

## 2.2 Alignment Selection

Railway selection alignment for new lines refers to the direction and position given to the centre line of the railway track on the ground in the horizontal and vertical planes. Horizontal alignment refers to the direction of the railway track in the plan including the straight path and the curves. Vertical alignment refers to the direction it follows in a vertical plane including the level track, gradients, and vertical curves where exist.

### 2.2.1 Optimising route alignment

The following aspects require special attention:

- The construction of the railway line should be as economical as possible
- It is necessary to have the shortest and most direct route between the connecting points.
- The alignment of the line should be so chosen that the construction cost is minim. This can be achieved by a balanced cut and fill of earthwork, minimizing rock cutting and drainage crossings by locating the alignment on watershed lines, and such other technical considerations.
- Maintenance costs can be reduced by avoiding steep gradients and sharp curves which cause heavy wear and tear of rails and rolling stock.
- The alignment should be such that the operational or transportation expenses are the minimum. This can be done by maximizing the haulage of goods with the given power of the locomotive and providing traction mix solutions – on the same line should operate even diesel traction solution but also electricity traction units.
- Adopting supplementary solutions, achieved in the design stage: easy gradients, avoiding sharp curves.

The alignment should be such that it provides maximum safety and comfort to the travelling public. This can be achieved by designing curves with proper transition lengths, providing vertical curves for gradients.

Aesthetic aspects should be considered when choosing the alignment. In this direction should be avoided views of borrow pits, poles for electrical power supply and passing the alignment through natural and beautiful surroundings with scenic beauty.

There are the geographical points through which the railway line must pass due to political, strategic, and commercial reasons as well as due to technical considerations. The following situations could be considered restrictions points:

- Fixed and obligatory points for a new railway line are considered intermediate important towns, cities, or places which are important from commercial, strategic, or political reasons.
- Suitable bridge sites for new construction become restriction points for a good alignment, because major bridges for large rivers is very expensive and difficult to realise.
- Should be identified also existing passes and saddles for crossing a hilly terrain in order to avoid deep cuttings and expenses for terrain works.
- The option of a tunnel in place of a deep cut in a hilly terrain is better from an economical point of view. This place for such of tunnel becomes an obligatory point.

The alignment must pass through areas not in danger of being flooded. Climatic conditions must be also considered for line way designing. In hot climate areas and sandy soil, the alignment should be made by those sections protected from the wind. Similarly, in cold regions, alignment should pass through these sections of land that are downwind, which can bring snow on line.

The selected alignment line should normally run on good and stable soil formation. Weak soil and muddy land present a number of problems and mainly those of maintenance. Though rocky soil provides a stable formation even involves more costs at construction stage.

The availability and proximity of local labour and good and cheap building material should also be considered when deciding the alignment.

Railway stations and yards should be located on level stretches of land, preferably on the outskirts of a town or village so as to have enough area for the free flow of traffic.

The alignment should avoid religious and historical monuments, as it is normally not possible to dismantle these buildings.

A railway line should cross a road at right angles so as to have perpendicular level crossings and avoid accidents.

The alignment should be such that the cost of construction of the railway line is as low as possible. Not only the initial cost of construction but also the maintenance cost should be as low as possible. For this purpose, the alignment should be as straight as possible, with least earthwork, and should pass through a terrain with good soil.

The alignment should be so selected that it attracts maximum traffic. In this context, traffic centres should be well planned, so that the railway line is well patronized and the gross revenue of traffic is as high as possible.

Having various considerations, it should be ensured that the alignment is overall economic. For this purpose, various alternate alignments are considered and it is chosen the most economical one, which is cost-effective and gives the maximum returns.

### 2.2.2 Mountain alignment

The levels in mountains vary considerably, and if normal alignment is adopted, the grades would become too steep, much more than the ruling gradient (allowable gradient for traction to be realised).

The gradients of mountain tracks are very steep. Normally tracks with gradients of 3 per cent or more are considered mountain tracks.

Normally narrow gauges with gauge widths of 762 mm or 610 mm are adopted for mountain railways.

The curvature of mountain tracks is very sharp; curves of up to 40° are normally adopted.

In order to remain within the ruling gradient and the train to have enough traction power, the length of the railway line is increased artificially for achieving a gradient to be in permissible limits.

Mountain alignment is almost zigzagged in order to gain heights easily. The type of alignments commonly followed are zigzag, switchback, and spiral.

Mountain railways have mostly been constructed for tourist traffic. In some cases, they may be constructed for exploiting hinterland or new areas.

In the case of very steep gradients, much steeper than 3 %, it becomes difficult for a locomotive to pull the train load and hence is possible for the train to slide down or slip back along the down grade.

The cost of construction of mountain railways is quite high because of the need for a large number of bridges and heavy earthwork. The cost, however, gets considerably reduced by adopting the narrow gauge (0.762 m or 0.61 m), and then it is possible to have very steep gradients and sharp curvature. This solution is feasible if the mountain track is quite isolated and are not connected to national railway network, with a standardised gauge dimension. Otherwise is recommended to keep one gauge system at national level.

Other solution to help traction of the locomotives is to adopt the rack railway system which is dedicated solution for mountain railways with steep gradients. The rack railway system consists of three rails - one extra toothed rail in the middle in addition to the two normal rails. The locomotive also has a toothed pinion wheel whose teeth fit into the grooves of the central toothed rail. This locking arrangement helps to haul the train load, to provide extra traction and braking and does not let the locomotive slip back. With the help of this system it is possible to move trains even on very steep gradients such as 1 in 5.



Figure 2.1 - Rack railway system <sup>23</sup>



Figure 2.2 - Rack Railway detail <sup>24</sup>

The rack railway system was developed and is used in many countries and regions around the world: Brazil, France, India, New Zealand, Germany, etc.

### 2.3 Choice of gauge for new lines and conversion of existing gauges

The choice of gauge is very limited, as each country has a fixed gauge and all new railway lines are constructed to adhere to the national standard gauge.

---

<sup>23</sup> (Source: <http://www.harrachov.com>)

<sup>24</sup> (Source: Copyright : © Tim Graham / Alamy Stock Photo)

### **2.3.1 Problems caused by multi - gauge system**

Multi gauge system existence are known as break of gauge. Uniformity of gauge has been considered necessary by all the countries with advanced railways networks. A number of problems are highlighted in the operation of multi gauge railway system, as follows.

Passengers have to change trains in the same journey, with their luggage; missing connections with the later trains in case the earlier train is late; delay in reaching the destination.

Goods have to be trans-shipped at the point where the change of gauge takes place which may cause damage to goods, considerable delay in the delivery of goods at the destination. That means difficulty in trans-shipment of goods

Wagons or engines of one gauge cannot be moved on another gauge that means low yield of rolling stock.

Due to change in the gauge, traffic of goods and passengers cannot move fast, becoming a major problem particularly during emergencies such as war, floods, and accidents.

More facilities and equipment, such as yards and platforms, need to be provided for both gauges at trans-shipment points.

Industrial centres cannot send their goods economically and efficiently to areas being served by stations with different gauges; the difference in gauge conducts to unbalanced economic growth.

The multi-gauge system is not only complicated and having great costs but causes bottlenecks in the operation of the railways networks and represents hinders to development of the country.

### **2.3.2 Advantages of a one gauge system**

The one gauge system will have benefits for rail users, the railway administration, but also for entire region and even to entire national country.

- Will be decreased problems with trans-gauge shipment, delays and damaging of goods, inconvenience to passengers.
- Transport bottlenecks will decrease significantly after a uniform gauge is adopted and this will lead to improved operational efficiency resulting in fast movement of goods and passengers.
- One gauge system permit alternate routes to be available for traffic movement and there will be less pressure on the existing network.
- Will be improved utilization of tracks and reduction in the operating expenses of the railway.
- The areas with economic problems will be helped, reducing regional disparities and balancing economic growth. The one gauge policy will help in providing these areas a better transportation infrastructure. Some of the areas served by the multi gauge railway system will have an increased potential of becoming highly industrialized. This will also help in setting up industries in areas not yet exploited because of the lack of infrastructure facilities.



**Loading gauge** represents the maximum width and height to which a rolling stock unit can be built or loaded. Frequently, a loading gauge is used for testing loaded and empty vehicles as per the maximum moving dimensions prescribed for the section.

The fixed structures on railway lines (bridges, tunnels, and platforms) are built in accordance with the standard current gauge, which means clearances on the sides and top. The construction or conversion gauge is could be done by adding the necessary clearance to the loading gauge so that vehicles can move safely at the prescribed speed.

There is only a marginal increase in the cost of the track if a wider gauge (most difficult and expensive variant of changing gauge) is adopted; with this consideration, the following points are important:

- There is a proportional increase in the cost of acquisition of land, earthwork, rails, sleepers, ballast, and other track items when constructing a wider gauge.
- The cost of building bridges, culverts, and tunnels increases only marginally due to a wider gauge.
- The cost of constructing station buildings, platforms, staff quarters, level crossings, signals, etc., is almost the same relating to gauges types.
- The cost of rolling stock is independent of the gauge of the track for carrying the same volume of traffic.
- The type of traction and signalling equipment required are independent of the gauge.

In the most cases, changing the gauge dimensions are represented by widening of the gauge; this is the most difficult and expensive situation and for this reason wider gauge is treated as bringing large benefits: can carry larger wagons and coaches; has a greater potential at higher speeds, because speed is a function of the diameter of the wheel, which is limited by the width of the gauge.

## 2.4 Rail Grade Selection

In recent years, the amount of traffic that the railways have to carry has increased and this is expected to continue into the future, combined with higher speeds has meant that the duty conditions of rail have become more severe. To combat this new harder rail grades have been developed by the rail manufacturers, which have become better understood through extensive laboratory and track testing.

An important aspect in the safety and maintenance of railways is the degradation of rail. Therefore for a cost effective railway an optimized rail grade selection is possible. For this is important to understand the degradation of different rail grades. Could be implemented cost effective maintenance strategy, means reducing of the life cycle costs, if the rate of degradation is known.

InnoTrack project has reached a high level in rail degradation analysis based on information gathered from infrastructure managers and rail manufacturers. This information cover the period of decades and allow a fair characterization of the phenomena of rail degradation – see Chapter 1.6.

The results have demonstrated that wear and rolling contact fatigue can be related to the track geometry, especially the radius of curves, and to the loading conditions.

### 2.4.1 Guidelines for rail grade selection

The present guidelines or national regulations for rail grade selection on mixed traffic lines with up to 22.5 tonne axle load and at least 20 MGT annual loads show a wide variation between the different railways, especially for the shallow curves with radius less than 1500 m. While in Italy, Ireland and the UK, grade R260 is recommended for the whole range of curvature, other several countries use R350HT for up to 500 m or 700 m wide curves to combat wear.

DB recently increased their guidelines for the use of R350HT to 1500 m while ProRail in The Netherlands and ÖBB in Austria recommend heat treated rail for curves up to 3000m to combat RCF. Banverket in Sweden also use heat treated rails for curves up to 3000m for the heavy haul Malmbanan line.

Radius [m]	≤ 300	400	500	600	700	800	1200	1500	2500	≤ 3000	> 3000	
UIC	R350HT		R350HT/R260			R260						
Germany	R350HT (≥ 30 MGT)					R260						
Germany - New Track	R350HT (≥ 50 MGT)								R260			
Switzerland	R350HT		R320Cr/R350LHT			R260						
Switzerland (Trial)	370LHT		R350LHT		Bainitic		R260					
Austria	R350HT		R260									
Austria (New) Single Track	R350HT		R260									
Austria (New) Double Track	R350HT										R260	
Sweden	R350HT		R260									
Sweden (Malmbanan)	R350HT										R260	
Norway	R350HT					R260						
UK	R260											
Ireland	R260											
Italy	R260											
Belgium	R350HT					R260						
Luxembourg	R350HT					R260						
Netherlands	R350HT/400HB		370LHT/400HB								R260	
Denmark	R350HT					R260						
Poland	R350HT					R260						
Hungary	R350HT					R260						
Romania	R350HT					R260						

Table 2.1 - Summary of present national guidelines for rail grade selection on mixed traffic lines with up to 22.5t axle load and at least 20 MGT annual loads <sup>25</sup>

A summary of the current pearlitic rail steels in use in Europe is given in Table 2.2 below. The grades are designated according to their minimum hardness. The grades R200 and R220 are still found in track but rarely used for new build tracks.

<sup>25</sup> InnoTrack Deliverable D4.1.3 - Interim Guidelines on the selection of rail grades; 2006

Rail Grade	EN13674 - 1: 2003[4]	Running Surface Hardness Range (HB)	Min. Ultimate Tensile Strength (MPa)	Min. Fracture Toughness $K_{Ic}$ (MPa.m <sup>1/2</sup> )		Description	Chemistry	Branding lines
				Single	Mean			
R200	Yes	200-240	680	30	35	C-Mn		None
R220	Yes	220-260	770	30	35	C-Mn		=====
R260	Yes	260-300	880	26	29	C-Mn		=====
R260Mn	Yes	260-300	880	26	29	C-Mn		=====
R320Cr	Yes	320-360	1080	24	26	1%Cr		=====
R350HT	Yes	350-390	1175	30	32	C-Mn Heat Treated	R260 + up to 0.15%Cr	=====
R350LHT	Yes	350-390	1175	26	29	Low Alloy Heat Treated	R260 + 0.30%Cr	=====
370LHT	No	370-400		Equal to or better than R350HT		Low Alloy Heat Treated	R260 + 0.50%Cr	Depends on Manufacturer
400HB	No	381-408	1280			Alloy Heat Treated	R260 +Cr+Si	Depends on Manufacturer

Table 2.2 - Pearlitic rail steel grades available in Europe <sup>26</sup>

#### 2.4.2 New developed criteria for Rail Grade Selection

UIC leaflet 721 gives recommendations for the selection of rail grades. The criteria for the choice of rail grades for mixed passenger and freight traffic railways with a maximum axle load of 22.5 t include:

- Local parameters (radius, tonnage carried, gradients (20‰ and more), speed and cant, axle load, type of rolling stock);
- Rail maintenance methods (lubrication and rail grinding);
- Economic assessment (investment cost, annual maintenance cost and service life time);

The UIC leaflet 721 gives recommendations for the rail grades that can be classes as standard and hard. The standard grades are R260 and R260Mn and the hard grades are R350HT, R350LHT and R320Cr (see Figure 1). The grades R200 and R220 are not recommended anymore for mainline railways.

<sup>26</sup> InnoTrack Deliverable D4.1.3 - Interim Guidelines on the selection of rail grades; 2006

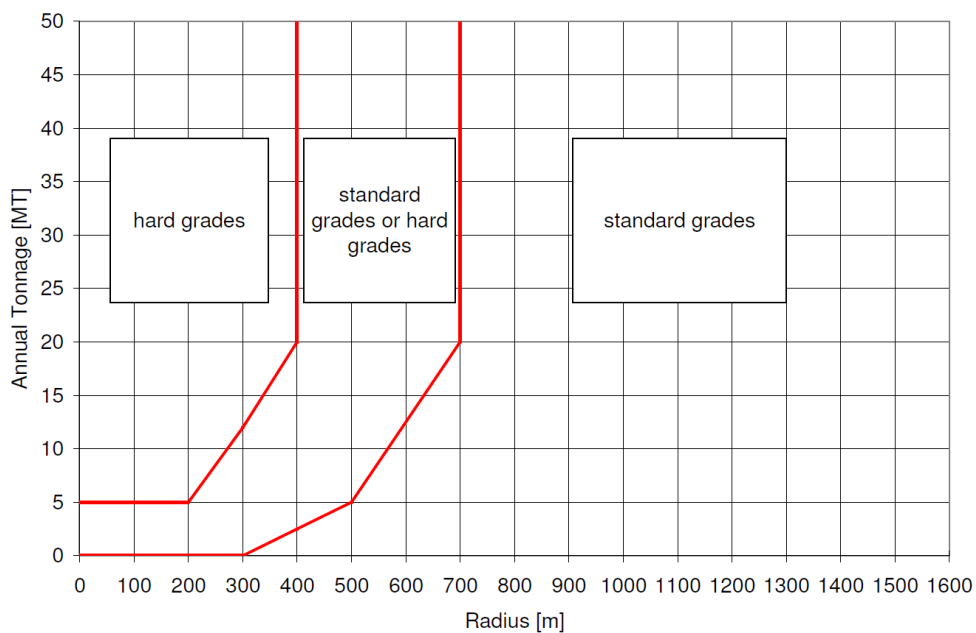

Figure 2.3 - Recommendation for the use of standard and hard steel grades according to UIC Leaflet 721 <sup>27</sup>

#### 2.4.2.1 Local Parameters

- Curve radius is one of the most influencing parameters on wear and RCF and thus the technical recommendations will use it as its initial parameter.
- The actual amount of tonnage carried over a time interval does not influence the kind of failure occurring, but defines the degradation rate and thus influences the maintenance strategy, the total life time of the rail and finally the economic justification of rail grade selection.
- Gradients and locations where acceleration and braking occur, e.g. stations, signals, increase the longitudinal traction forces on the railhead. Degradation at these locations includes: wear, corrugation, wheel burns and RCF. The degradation mechanism at these locations is also influenced by the curvature as well. On tangent tracks with high line speed it has to be considered, that the engines run with high power and under full slip conditions while running with constant speed to overcome the aerodynamic and rolling resistance of the train. RCF like Head Checks and Squats or Corrugations may therefore initiate.
- The actual driven speed and its distribution, along with track geometry, influences the transverse position of the vehicles in track and thus the loading and degradation mechanisms of high and low rail. An example of damage arising because of high cant, low speed and high axle loads is field flow and crushing of the rail head for the low rail of curves.
- The axle load together with the wheel rail profiles and tangent contact forces defines the working point according to Johnson's shakedown map leading to different material behaviour. In the regimes of cyclic plasticity and ratchetting the material will fatigue and the

<sup>27</sup> InnoTrack Deliverable D4.1.3 - Interim Guidelines on the selection of rail grades; 2006

degradation mechanism observed on the rail will be both wear and RCF or severe wear without crack propagation if the slip is high enough to remove initiated surface fatigue cracks.

- The type of rolling stock is also a factor on the degradation of the rail. The severity of impact depends on the wheel diameter, the curving behaviour (including primary yaw stiffness) and, for the driven axles, on the kind of traction control. This may result in full rolling, stick slip or full sliding conditions at the contact patch.

#### **2.4.2.2 Rail maintenance methods**

Properly applied lubrication of the high rail leads to a significant reduction of side wear on the high rail and some reduction vertical wear and prevents the so called “rutting” corrugations on the low rail of tight curves too. Due to the reduced wear by applied lubrication an increased growth of RCF-cracks might occur.

Rail grinding is a common maintenance procedure to improve contact conditions and extend rail life by reaching the optimum wear rate with artificial metal removal. The improvement would be enforced further by parallel use of a higher steel grade.

#### **2.4.2.3 Economic Issues**

The economic consideration is the most relevant criteria and should result in reduction of LCC.

There are several hidden costs which can be described by the RAMS-technology but they are harder to quantify. Two fields of RAMS, safety and availability, will influence the acceptance of private and business customers for railway services. Including cost figures for these items will increase the maintenance and operation cost for LCC calculation. The increased investment cost of premium steel grades for rails will be justified by decreased cost for maintenance and also will result operations with better performance, better safety and better availability. The result is a reduction of total LCC.

#### **2.4.3 Recommendations for Rail Grade Selection**

The rail grade classes recommended in UIC Leaflet 721 have to cover a wide field of loading conditions. Since the results from field test show both a reduced wear and RCF-crack growth rate for the head hardened pearlitic grades, improvement in LCC could be expected principally for high annual tonnage by the use of R350HT/R350LHT in this range. Assuming that the expectation of doubling passenger traffic and tripling freight traffic by 2020 would occur, can be summarised evident consequences:

- The annual tonnage on railway lines rises.
- The maximum axle load would be exploiting by an increased proportion of traffic or would rise.
- The higher line efficiency requires shorter time slots for maintenance.

Thus to ensure sustainability, for tighter curves where higher contact stresses occur the higher hardness grades are recommended for both high and low rail. The grades recommended include those with a hardness of approximately 400HB, which are not currently specified in EN13674-1.

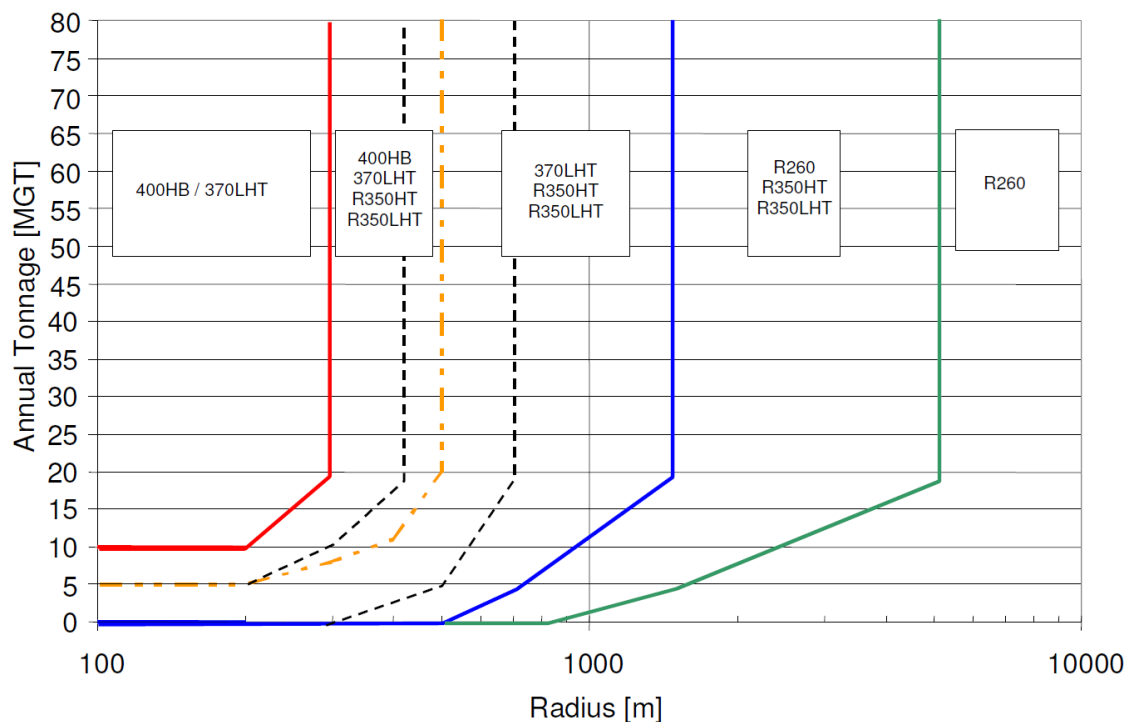

Figure 2.4 - Recommendation on the selection of standard and different hardened rail grades. The dashed black lines mark the boundaries shown in Figure 2.3

#### 2.4.4 Conclusions

The collated data have demonstrated that it is possible to investigate trends in rail degradation for both wear and rolling contact fatigue. The InnoTrack studies have confirmed the general assumptions:

- Wear increases with increasing rail curvature (decreasing radius), with a greater effect for 45° wear than for vertical wear.
- The wear rate of harder premium grade rail steels is lower than for standard rail steels on the same curve types.
- Rolling contact fatigue, in the form of head checks, is most prevalent on curves of 700 -3000m radii.
- Premium grade rail steels are more resistant to RCF initiation and growth.
- For a given surface crack length the depth of the associated crack is less for harder rail steels than for standard grades.

Segmentation of a section of a mixed traffic railway has been carried out and the rail degradation algorithms have been applied to predict the degradation of each segment.

#### Wearing rail mechanism:

- The life determining factor for the majority of the route will be vertical wear with a maximum rail life of approximately 30 years
- Curves with radii of less than 1000 m exhibit significant amounts of 45° (and side) wear, with the amount of wear increasing with decreasing radii.
- There is no benefit of installing premium grade rail steels in curves of greater than 900m with respect to wear.

- In respect to the section of track that has been analysed. The fitting of premium grade rail steels to curves of less than 700m curves requires 6.5% of the track to be fitted while improving the life significantly for only 2.5% of the total route.
- Rail grade selection criteria should be based on the known degradation mechanisms and rates and not solely on track radii and the amount of traffic carried.

#### **Rolling Contact Fatigue (RCF) Mechanism:**

- The use of premium grade rail steels result in lower RCF crack growth rates with magnitudes of improvement depending on the curvature and amount of traffic.
- The proportion of the route with higher growth rates is reduced as the premium grades are applied to curves with increasing radii, up to a maximum radius of 3000 m.
- The proportion of the route to be fitted with premium grade rails will depend on the amount of grinding capacity available and a life cycle cost analysis. The latter requires the correct balance between the higher material costs and a reduction in maintenance costs resulting from an increase in the interval between grinding operations, which in turn is a result of the lower crack depth growth rates of premium rail steels.

## **2.5 Main influencing variables on costs of logistic chain for new lines rail supply**

The logistics chain is one of the most important issues when the supply of rails is considered. In order to optimize the delivery of rails an exact understanding of the logistics path of a rail from the rolling mill to the installation site is strongly required, as there are several delivery alternatives and associated needs, these different possibilities have to be considered in evaluation regarding economic impacts.

### **2.5.1 Rail length**

The length of the rail represents a key parameter concerning the logistics of rails. It defines the number of required welds in track: the longer the rail produced in the rail mill, the less the required welds in field, or in a welding plant. This leads to a corresponding decrease in total welding cost and logistics expenditure not only during the installation process of rails in track. The utilisation of long or ultra-long rails provides significant LCC-reductions also during the operation period, since the majority of rail deficiencies and about 50 percent of rail breaks occur in welds. These obvious benefits created by the use of long rails in track have resulted in several rail manufacturers to convert their rolling mills to enable the production of long rails. This is however related to huge investments in both production and finishing lines as well as to major logistical process adjustments.

### **2.5.2 Rail welding**

Generally two different methods for rail welding are currently available (aluminothermy welding and flash-butt-welding). These are executed in track and also in special welding plants (flash-butt-welding).

In order to produce continuously-welded rail tracks, welding can be accomplished on the one hand in tracks only and on the other hand as a combination of welding in plants and in-track welding. In the second case welded rail strings with lengths up to 400 meters or more are produced in welding plants and must then be transported by special long rail units (LRU) to the site, where the remaining

welding is performed. In this context also the capital cost of the welding plant and of the LRU's must be considered.

### 2.5.3 Transportation

Concerning railway transportation of rails two types can be distinguished: "interrupted transport" and "direct transport". Taking into consideration logistic processes and logistics related costs "direct transport" should be favoured whenever possible. Additionally a just-in-time transportation of rails to the construction site allows a further minimization of manipulation actions as well as stock keeping and provides extraordinary advantages regarding logistics costs.

### 2.5.4 Stock keeping

Stock keeping requires plants and associated areas with appropriate railroad connections and available human resources. It ties capital, which leads to additional costs without increasing the value of the rails. The variables influencing the logistic chain of rail supply listed above are all reflected in the total logistics costs of rail supply. Depending on the mode of delivery these costs may differ considerably. In any circumstance they must be considered in addition to the pure material costs. Such an analysis will reveal benefits from new approaches towards logistics of rails (use of long rails, direct just-in-time transportation etc.). This will yield significant contributions to the minimization of logistic related costs and consequently a general LCC reduction.

### 2.5.5 Manipulation

Rail manipulation is a part of the supply chain that can be eliminated for direct rail installation in track, but is unavoidable when rail delivery follows the interrupted transportation mode and also for repair workshops. The manipulation requires human resources for the operation of the machines, associated maintenance activities, and all other actions connected to railway shops.

## 2.6 Crossing types for new installations or rebuilding railway lines

To define solutions for the optimization of S&C as components for rail, especially for new projects, information from the InnoTrack project will be used.

In this regard, we referenced the deliverables from the work package "Switches and Crossings (SP3)" from InnoTrack.

Next terms should be described:

**Short-range planned actions after inspection** – this expression signifies actions that include adjustment, build up welding and minimal repairs as actions after inspection.

**Long-range planned actions after inspection** – represents actions that include replacement of frogs, switch rails and check rails as part of the condition based maintenance

### 2.6.1 Cost drivers analysis

#### 2.6.1.1 Constraints for data analysis that should be considered:

- Inspection and service activities are based on planned maintenance;
- Insufficient infrastructure data bases for getting data of costs for maintenance with a detailed allocation to several components and maintenance actions;
- This is obviously a problem for all railways. Therefore as the solution adopted in SP 3.1 specific routes have been chosen and analysed;



- As far as possible representative lines are selected for the cost factor analysis;
- Operational aspects like use of deviating track, main direction of traffic, placing of S&C (close to bridges and curves) etc. should be part of further investigations because e.g. replacements of switch rails are highly influenced by the number of trains running on the deviation line.

### 2.6.1.2 Cost drivers for high speed line from DB (Deutsche Bahn) Railway

The analysis of the selected high speed line from DB (with UIC 60 S&C, mixed traffic with about 17.5 MGT/year (average) and 458 chosen S&C) has identified the following key parameters:

- 50% of the overall costs are for inspection, service and test measures. These are thus the main cost drivers overall at the selected DB line.
- Excluding inspection, service and test measures, the main cost drivers as total 65%, are for: renewal of half set of switch (35%); large elements cost 17% and frog renewal costs 13%.
- The other activities like welding, corrective maintenance (e.g. minimal repair), tamping etc. are in proportion of 35%.

Results from others DB analysis confirm this conclusions in general but show that the costs for renewal of switch rails are roughly equal to the costs for renewal of frogs. DB railway consumes most money for the frog renewal, second for maintenance including small repair, third for renewal of large elements and forth for switch rail renewal.

### 2.6.1.3 Cost drivers for high speed line from Banverket Railway

The chosen line for testing and analysis is line number 119 between Boden – Luleå. It is a mixed traffic line: about 25% passenger and 75% freight, which means that this line is freight dominated route. The highest axle load is 30 tons with estimation of the traffic to be 20 MGT/year (Million Gross Tons per year).

The main cost drivers, considering less inspection costs, less service costs and no test measures costs, are:

- Short-range planned actions after inspections represent about 30% of expense. These include: mainly adjustment; build up welding and minimal repairs. Even are actions after inspection, are seen by Banverket (**Swedish Rail Administration**) as immediate corrective maintenance.
- Long-range planned actions after inspection represent 26% costs, including replacement of frogs, switch rails and check rails as part of the condition based maintenance;
- Costs for inspections & predetermined maintenance represent about 17%.

The costs for these measures sum up to 73% while the amount for the other activities inspection, for grinding and tamping are about 27%.

The maintenance costs per units UIC60-300 and UIC60-760 are about the same on main track.

The maintenance costs on the main track are about 7.8 times higher than on the side track.

The InnoTrack project considers the following main components are of interest for analysis and optimization: switch rail; stock rail; frogs; check rail; fastenings; sliding chairs; blade rollers; plates; sleepers.

For DB and BV, the main costs are represented by cost factors of S&C (renewal of frogs and switch rails). This is the sufficient reason for optimizing of these components.

### **2.6.2 General Considerations for Switch and Crossings Optimisation**

It is obvious that for reducing maintenance costs for Switch & Crossings is necessary for optimization from technical point of view. The project InnoTrack led tests and simulations in this direction and obtained valuable results to reduce maintenance costs by increasing the reliability and performance of technical nature elements.

The measurements gave understanding of track dynamics in S&Cs especially because the real stiffness in switches is almost unknown until now. It is obvious that track stiffness can has variations along a track. These variations could be related to construction type (e. g. slab track versus ballasted track) but also for the same track with different sections type. For second reason, will be considered measurements for S&C as different category than those for plain track.

This category of measurement - real stiffness in switches - is almost unknown. At least in Europe there are only very few measurements that have been done.

This type of approaching have to be considered as very new: to develop optimized track related components of a switch with scientific methods and simulation tools with a European wide collaboration of suppliers, infrastructures and Universities instead of a time consuming “learning by doing”.

The objectives for the stiffness measurements adopted by InnoTrack project were:

- Continuous measurement of vertical stiffness along the switch
- Optimizing of stiffness in the frog and switch rail area in order to decrease wear and to increase life cycle time in respect to LCC reduction measurements.

Benefits for continuous stiffness measurements on S&C:

- Stiffness measurements can also be useful to verify the track after construction; especially that transition zones have been constructed according to plans.
- The condition of track and S&C concerning voids can be monitored. This could be useful for the “tamping on demand”.

### **2.6.3 Optimization Categories for S & C**

To achieve detailed measurement and performance analysis, the Switch & Crossings component was divided into three areas of panel type: switch panel; closure panel; crossing panel.

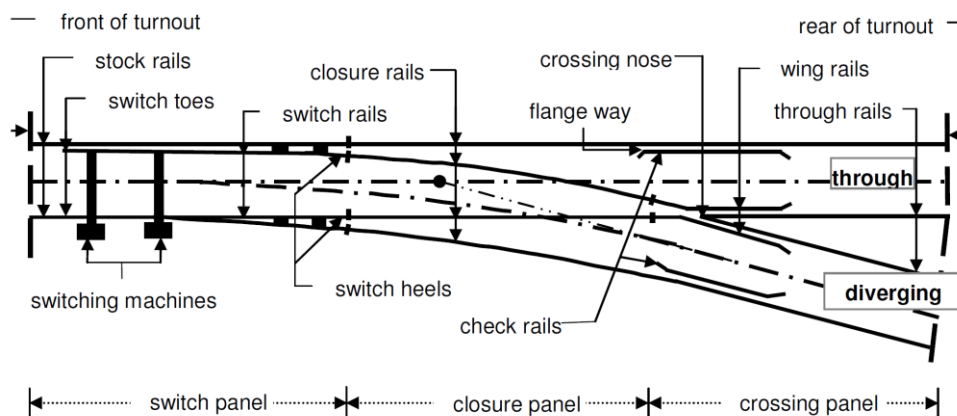

Figure 2.5 - Components of a turnout with through and diverging routes. (17)

**The through and diverging routes:** Traffic in the facing move means that traffic is travelling from the switch panel to the crossing panel. Consequently, traffic in the trailing move means traffic travelling in the opposite direction.

Categories of optimizations, applicable to S&C segments:

- The optimization of geometry and stiffness in the switch panel.
- Optimization of dynamic track gauge in the switch panel.
- Optimization of geometry and support stiffness in the crossing panel

The comparison of standard support stiffness with reduced support stiffness (by means of elastic rail pads) shows that the impact loads can be reduced considerably especially for crossing negotiation at high speed. Investigations of different crossing geometries show that it is difficult to find a solution which leads to a force reduction for all wheel profiles occurring in service.

*The MaKüDe crossing design showed the best performance especially for mean worn wheel profiles for both running directions (facing and trailing moves). In connection with reduced support stiffness (e.g. elastic rail pads), this crossing design will lead to a significant reduction of the impact loads and consequently a high potential for LCC reduction.*

### 2.6.3.1 Optimization of geometry and stiffness in the switch panel

In panel switch of S&C section, when a vehicle is running in the diverging route, large lateral wheel set displacements are developed leading to severe flange contact with the curved switch rail. This is mainly due to the abrupt change in track curvature and the large cant deficiency. Also, it has been observed that vehicles running on the through route in the switch panel, experience significant lateral wheel set displacements, sometimes leading to flange contact with the straight switch rail. These flange contacts result in an increase in wear of the switch rails and on some occasions in RCF problems on the rails, requiring increased inspection and maintenance but also leading to reducing life of the components.

For switch panel, optimization was mainly based on numerical simulations. Simulations of a train passing an S&C in both routes, and in facing and trailing moves, have been performed using the MBS package SIMPACK software modelling application, to understand the phenomena and to design a strategy for the optimization process. A freight vehicle model, with a car body and two Y25 bogies, is

used. The optimization process was performed for a standard S&C design (UIC60-760-1:15) with curve radius 760 m and turnout angle 1:15.

After optimization using simulation applications, was decided to perform a validation of the different software results through the field measurements in Härad (Sweden). After that was made a comparison of measured and calculated wheel–rail contact forces.

In May 2006, InnoTrack conducted a field measurement campaign in a turnout in Härad in Sweden. The turnout design and the measured results from Härad are being used as reference in much of the work performed in INNOTRACK deliverables. For example, wheel-rail contact forces measured in the turnout have been used to validate the computer models used in the project.

Output data from the measurements included lateral (Y) and vertical (Q) wheel–rail contact forces from an instrumented wheel set that was positioned as the leading wheel set (when travelling in the facing move) in the leading Y25 bogie of a freight vehicle. During the measurements, the freight vehicle passed the turnout in both the main and diverging routes at different speeds. The turnout was a design (UIC60-760-1:15) diverging to the right with curve radius 760 m, crossing angle 1:15 and 60E1 rails.



**Figure 2.6 - UIC60-760-1:15 turnout in Härad. (17)**

Wheel profiles were measured using MiniProf equipment. Rail profiles were also measured using MiniProf at some 80 positions on the left and right rails in the through and diverging routes. Track gauge was measured at the same positions. The rail profiles and track gauge were measured at every 10 cm in the crossing panel and at every 30 cm in the switch panel.

Based on the results from the field measurements, the influences of train speed, route and running direction on the maximum vertical contact force or impact load ( $Q_{max}$ ) at the crossing are determined. For all train routes, was observed that  $Q_{max}$  will increase with speed increasing.

Also, the increase in impact load is considerably higher for the diverging route as compared to the through route. In the through route, the contact force increases by a moderate 15 % when train speed increases from 10 km/h to 80 km/h. The corresponding increase in the diverging route is about 40 %. The influence of running direction (from wing rail to crossing nose in the facing move or vice versa in the trailing move) on  $Q_{max}$  was observed to be relatively small for both: the through and diverging routes.

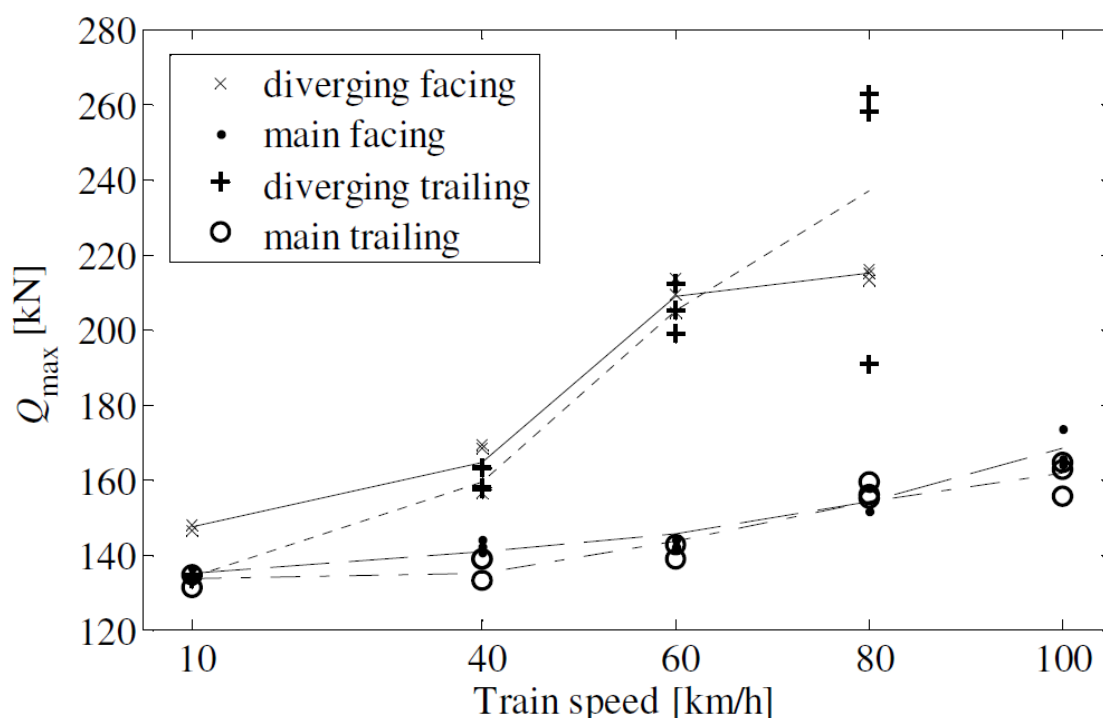

Figure 2.7 - Measured maximum vertical contact force (impact load)  $Q_{max}$  when the train is moving in the through or diverging route and in the facing or trailing move. The lines are least square fits to the measured values. (17)

Railway vehicles often experience significant lateral displacements, sometimes leading to wheel flange contact, when running in the switch panel. This leads to increased wheel and rail wear and sometimes RCF (rolling contact fatigue) problems on the rails, requiring increased supervision and maintenance and reducing the life of the components. Based on these considerations, two possible optimal solutions were found and validated in InnoTrack Project. The resulting benefits will be obtained by the new designs and they are: a significant reduction of wear along the switch; a significant reduction of traction coefficient, and therefore improved behaviour in terms of rolling contact fatigue.

The proposed geometry modification at switch entry could relieve the flange contact with the switch rail at the early stage by steering the wheel towards the other rail. In addition, with this geometry

modification, the tip of the switch rail could be thicker which gives more material for wear and hence reduces LCC for the switch.

For track stiffness optimization, two alternative stiffness variation models were considered. The stiffness variation is expected to be achieved by varying the rail pad stiffness along the switch panel and by applying under sleeper pads. Placing stiffer rail pads starting from some distance before the front of the turnout and softer rail pads close to the switch heel can improve the smoothing of the large change in track stiffness along the switch panel.

### **2.6.3.2 Optimization of dynamic track gauge in the switch panel**

The transfer of the load between the stock rail and the switch rail takes place a few meters after the stock rail enters the curved path. This means that the right wheel follows the diverging route for a few meters before jumping back to the straight route. In this area, an artificial increase of the gauge is taking place on the side of the switch, and therefore a rolling radius difference is generated between the two wheels, which induce a lateral movement of the whole wheel set towards the switch rail. When the load is finally transferred to the straight switch rail a sudden reduction of the gauge takes place on one side, which causes again the wheel set to be out of the central position.

To minimize the effect of this phenomenon on the performance of the switch, a number of possible solutions have been proposed. One of the solutions is applying a dynamic variation of the gauge on the straight stock rail.

Finding an optimal design for the dynamic gauge widening is performed by varying the values of the maximum gauge widening amplitude. Was considered a range between the smallest (8 mm) and the highest (20 mm) amplitude for experimental designs

From simulation and real measurements were observed that highest transients are happened between 8 to 8.5 m from switch entry. This occurs when the load is fully transferred from a two-point contact (the first contact point is the contact on the stock rail whereas the second contact point is the contact on the switch rail) to a single-point contact on the switch rail.

For the other studied gauge widening amplitudes, there is no significant change in the normal contact force before or after the contact jump.

It is observed that the application of a dynamic gauge widening leads to a reduction in wear index along the switch panel, and that the maximum value of the wear index is reduced considerably for gauge widening amplitudes 8 mm - 16 mm; 20 mm gauge amplitude leads to an increase in wear index, and the reduction using the 18 mm gauge amplitude design is not significant compared to the other designs.

The two designs of dynamic gauge widening (12 mm and 16 mm), which proved to be optimal in the facing move, were subsequently evaluated in the trailing move with respect to wear index.

For the 16 mm gauge widening, contrary to the facing move, the wear index is slightly increased both in the 1st and 2nd contacts. In addition, the location of the maximum wear index on the switch rail has shifted towards the switch toe, where the thickness of the switch rail is smaller. As in the case of the facing move, the 12 mm gauge widening amplitude leads to a significant improvement in

reducing the wear index. Therefore, the design corresponding to the 12 mm maximum gauge widening is the optimal design both for the facing and trailing moves.

For improving design of the switch panel design, the variation of geometry for a designed track gauge, in the switch panel, has been modelled in InnoTrack project. For traffic in the facing and trailing moves of the through route, an optimum solution was identified and then validated by evaluating a wider set of simulation cases (different wheel profiles). The optimum design includes a 12 mm maximum gauge widening. The main benefits obtained by the proposed design are a significant reduction of wear along the switch panel and a significant reduction of traction coefficient, and therefore improved behaviour in terms of RCF. The methodology can be applied also to other types of turnout designs.

For diverging route were considered the three levels of increased maximum gauge: 8 mm; 12 mm; 18 mm. From InnoTrack simulations and experimental results, no significant improvement is obtained with respect to the wear index for any of the three levels of gauge widening amplitudes.

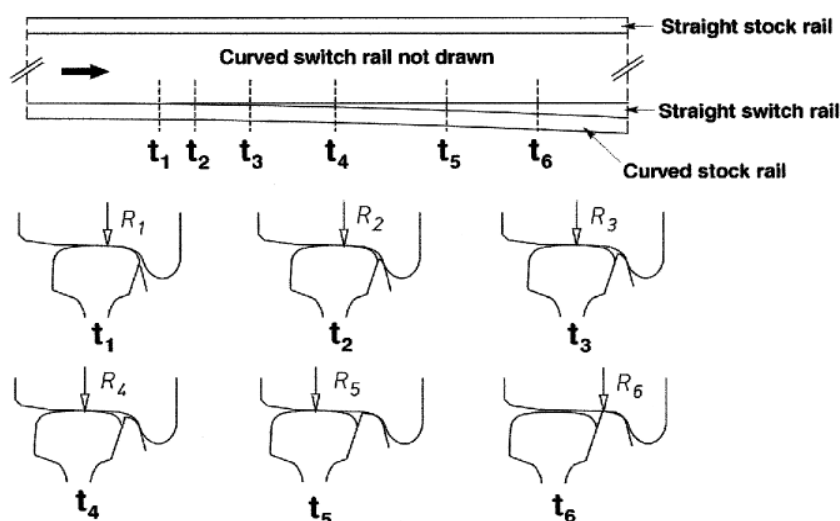

Figure 2.8 - Trajectory of the contact patch on the stock and switch rails <sup>28</sup>

Based on the performed simulations, it has been shown that the application of gauge widening in the switch panel has a strong potential in reducing wear and RCF.

### 2.6.3.3 Optimization geometry and support stiffness in crossing panel

Severe impact loads may be generated when the wheels are transferred between wing rail and crossing nose in the crossing panel. The objective of InnoTrack studies in this direction were to optimize the crossing geometry and the support stiffness of the superstructure in order to reduce the contact stresses induced by the wheels.

<sup>28</sup> From Bugarín M R Diaz de Villegas J M, "Improvements in railway switches", Proc. IMechEng. Part F. Journal of Rail and Rapid Transit, Vol. 216, pp. 275-286 (2002)

If it is possible the optimization of the vertical wheel movement (minimizing this movement), during the transition between wing rail and crossing nose, the gradient of the vertical wheel lift can be reduced after the transition point; this improvement leads to smaller impact loads on the crossing nose.

Solutions for modifying geometries of the crossing panel (crossing nose and wing rail) that are possible and have good results:

- Reduction of the flange way width between crossing nose and wing rail will have results to shift the wheel transition area to a thicker cross-section of the crossing nose;
- Modification of the nominal crossing nose profile (straight ramp) into a convolute ramp will decrease the gradient of the vertical wheel movement after transition to the crossing nose (optimization for facing move)
- Super elevation of the wing rail and re-profiling it to a proper match with worn wheel profile, will reduce the vertical wheel movement (MaKüDe model);
- Modification of the wing rail profile with a cutting will allow wheels to climb up the wing rail with reduced impact forces (optimization for trailing move).

The modified wing rail design type “MaKüDe” considers to provide a transition geometry which leads to a nearly horizontal wheel movement. The ramp of the crossing nose was adapted to reach a smoother transition.

Wing rail profile modification was initiated from the problem of damaged wing rails due to hollow worn wheels passing in the trailing move. In the trailing move, the outer section of the hollow worn wheel arrives to deep and hits against the profile corner of the wing rail. To avoid this, a small chamfer was added on the rail flange to reduce the contact angle when the wheel is transferred to the wing rail.

Comparing standard support stiffness with reduced stiffness values – with elastic rail pads, has determined that the impact loads can be reduced considerably especially for running at high speed at crossings.

The InnoTrack project investigated several different crossing geometries to quantify the influence of maintenance tolerances and to find an optimal design for the crossing nose and wing rails. The MaKüDe design developed by DB Systemtechnik showed the best performance especially for mean worn wheel profiles for both running directions (facing and trailing moves). In connection with reduced support stiffness (e.g. elastic rail pads), this crossing design will lead to a significant reduction of the impact loads and consequently a high potential for LCC reduction.

According to the simulation results, the conclusion can be drawn that for the most common wheel shape (represented by the mean worn wheel profile) the MaKüDe design would be the best choice as crossing geometry. It is concluded that this crossing design will lead to a significant reduction of the dynamic impact loads and consequently a high potential for LCC reduction.

## **2.7 Technologies for replacement of Switches and Crossings (18)**



Switches and crossings represent a key asset of the railway infrastructure, which must be replaced with higher frequency than plain track given that they have to bear higher stress. There is a wide range of methods being used to replace switches and crossings (S&C), which offer different outputs and installation qualities.

Track stiffness variation along the switch has a direct effect on the magnitude of impact loads that cause track deterioration

Switches are not only placed in the infrastructure to connect different lines, but also to connect parallel tracks of the same line (crossovers) in order to give flexibility to track operation. The operational impact caused by an incident on the track is directly related to the number of crossovers in the line, which are their importance for IMs.

Moreover, because of their configuration, turnouts represent a singular and particular segment in the track. Compared to plain track, S&C have higher track stiffness given that they are provided with altered sleepers dimensions and arrangements, additional rail elements, etc. In relation to the adjacent track, the conditions of the wheel-rail interface vary significantly given the rail geometry discontinuities of the switch. This results in an increase of wheel dynamic loads that deteriorates the switch, especially the crossing nose and blades that receive the impact loads, causing wear, RCF – rolling contact fatigue – and noise.



**Figure 2.9 - Switch in a dual gauge line in Spain (source: Adif)**

Switches must be kept in good condition in order to guarantee an adequate running of the train through switch, and thus, to minimize its degradation by dynamic loads. If not properly maintained, the wheel-rail interface will be negatively affected, which could eventually derive in derailments (e.g. as a result of the wheel impacting a blade that is not correctly coupled to the stock rail or suffers excessive wear).

Because of safety and operational issues, switches are intensively inspected and maintained. Inspection costs account for the 50% of all maintenance costs for switches. In spite of the high investment on maintenance, switches have a lesser lifespan than plain track given that they suffer higher stress.

Due to the high number of switches being replaced every year (e.g. over 2000 in Germany), efficient methods in terms of cost and time have to be employed to minimize the impact on operations. Moreover, future performance of the new switches depends strongly on the quality of installation.

In this chapter, related to replacement of switch and crossings, are presented studies results and information from MainLine Project, Deliverable 3.3.

### 2.7.1 Classification of S&C replacement methods

Three main methods for S&C renewal can be identified:

- Assembled in situ.
- Pre-assembled in the vicinity of the works.
- Modular switch (just in time).

According to DB (Deutsche Bahn), the proportions of these three methods is 9% pre-assembled in situ, 90% pre-assembled in the vicinity of the works, at the lineside, and less than 1% for modular switch. This proportion is very similar to the majority of the countries analysed in the report. Only in some Eastern European countries the proportion of switches assembled in situ is higher. In contrast, Network Rail uses the modular switch concept with certain frequency.

As a result can be admitted that assembly of the S&C adjacent to the worksite is the most common practice across Europe due to the following advantages:

- On acceptance of the S&C at the factory, disassembly, transport and reassembly near the renewal site is relatively straightforward.
- S&C can be constructed near the worksite and installed with minimised disturbance to traffic.
- The quality of the components and installed geometry is known to be good upon commissioning.

**Modular switch** concept is expected to grow in some countries given that this method allows a reduction of not only the installation time but can also facilitate significantly the pre-renewal works (no need to negotiate with landowners if there is no available space for the assembly of the new switch) and post-renewal works (less time required for commissioning).

It is important to remark also that in some countries, especially in Eastern Europe, piecemeal is still a common practice. Piecemeal renewal leads to a lower quality of the switch since S&C units end up with components of varying age and condition.

### 2.7.2 Phases of S&C replacement methods

As it was mentioned before, there can be found a wide range of methods for replacing a turnout, nevertheless, all replacement methods follow a similar structure, which can be organized in four main phases.

Pre-renewal works:

- Preparation of storage areas;
- Transport of replacement components to site;

- Pre-assembly of the new switch in the storage area (in case it is required);
- Topography works previous to installation;

Removal of the old S&C and site preparation

- Dismantling and removal of the old S&C
- Removal of the upper part or the whole layer of ballast

Installation of new S&C:

- Adding of new ballast (and optionally placing of geogrid)
- Laying and assembly of the new switch panels
- Welding or clamping
- Initial track geometry restoration
- Control system commissioning
- Final commissioning and testing
- Dynamic Track Stabiliser (optionally)

Post-renewal activities

- Welding and stress release (if it is not done during the installation phase)
- Final track geometry restoration
- Final inspection and acceptance

### 2.7.3 German practice (DB)

According to DB, around 2000 S&C on average are replaced annually in Germany. The switches are supplied by a factory owned by DB Netz and by two other factories in Germany. The latter two factories supply nearly 75% of all the switches.

The criteria to decide which method should be used during the S&C renewal are based on economic aspects, and for that reason the most common method is the **pre-assembling near the site** (90%). Usually there is lineside space available for the pre-assembling of the S&C and track access roads to transport the switch components and machinery. In practically 99% of cases, heavy railway cranes (up to 40 tons) are used for installing the new switch panels on their final position. Other installation systems such as UWG system, excavators or VAIA-Car crane-beam are infrequently used.



**Figure 2.10 - Multi-purpose railway crane commonly employed for switch renewal. (Source: DB).**

When there are lineside space constraints to the preassembly of the switch, such as in tunnels or embankments, the modular switch method is preferred. The modular switch renewal concept accounts for only 1-3% of the total S&C renewals. One of the main reasons of this low use of the modular concept is the reduced number of special tilting wagons available for the transport of switch panels from the factory to the worksite.

DB owns a total of 8 special tilting wagons, known as Weichentransportwagen (WTW). Considering that replacements take place during weekends (52 a year) and that usually 3 WTW are used to transport the total switch, around 100 S&C replacements take place annually with this system (which is consistent with the 1-3% of the total renewals mentioned above).



**Figure 2.11 - Tilting wagons used to transport switch panels from factory. (Source: DB).**

Around 7 to 9% of S&C renewals are done using the assembly in situ method. This method is also very rarely employed given that it requires longer track possession and involves high labour costs.

DB Netz intends to implement “plug and play” techniques in the future to speed up replacement and commissioning of components interfaced with the signalling system (e.g. point motors) by using computerised self-testing.

Usually, DB practice during switch renewal is to clamp the rails during installation and carry out the welding before the line is reopened, which is usually at line speed as long as the ballast has been tamped to restore track geometry. In some cases, line is opened before the final track geometry

restoration is done, and temporary speed restrictions (TSR) apply until a certain amount of traffic has passed.

#### 2.7.4 Spanish practice (COMSA)

The most common S&C replacement method employed in Spain is the pre-assembled on site method (95%). The assembled in situ method is only a valid option if the switch must be built in a new line or line is closed for several days for track works.

The system used for the renewal of the switch depends strongly on the dimensions and weight of the switch (or of the panels into which the switch is divided). Additionally to the dimensions and weight, quality of installation is also a decision-making driver in some cases, such as in high speed lines. In Spain there are mainly three different methods for replacement: portal cranes (Geismar-Fasseta), crane-beam or special crane systems (Vaiacar or Desec), and rail/road excavators.

The use of excavators is the most common method in conventional lines, since it is usually the most economical. To remove the old switch and to install the new switch, two hi-rail excavators are used. When there is a parallel track, the hi-rail excavators run over it from the storage area till the location of the switch renewal. Given that their load capacity is between 5 and 8 tonnes, and also to minimize the deflection during transport, the switch is usually divided in three panels: switch panel, closure panel and crossing panel.

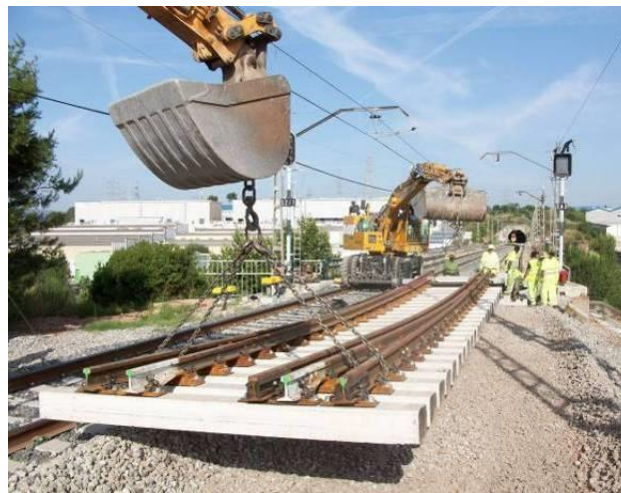

Figure 2.12 - Installation of new switches in segments by rail-road excavators (source: COMSA).

Apart from the excavators, **crane-beam systems** are also used in the Spanish **conventional rail network** but very occasionally, due to the fact they incur usually in a higher cost. They could also be used in high speed lines, but given that the lengths of the switch can be over 60 m and its weight higher than 60 tonnes, the use of two crane-beam systems attached (tandem) would be required. However, as it will be described further on, in these cases the solution of portal cranes, such as Fasseta solution, is preferred.



Figure 2.13 - Installation of a switch with VAIACAR crane-beam system. COMSA.

The installation of a switch in a **high-speed line** is treated differently from that of a conventional one, since the dimensions and weight are much higher but also because of the complexity of the switch. In comparison to the 30-50 m length of a common switch for conventional lines, switches allowing speeds on the deviated line higher than 200 km/h can have lengths of up to 175 m in total and weigh over 200 tons.

As a consequence, even if they are divided in three parts, crane-beam systems or excavators cannot bear with them. The solution employed in these cases is the **portal crane system** (Geismar-Faseta in the case of Spain).



Figure 2.14 - Installation of a switch panel by portal cranes. (source: COMSA).

This system is composed of a set of completely independent machines which lays pre-assembled points or crossings in one or more sections depending on its length. This machine loads and unloads the points or crossings, moves them laterally or longitudinally and installs them (on existing or new track). The system's versatility means that it can be used during track replacement works.

It has to be said that given that the installation of these high standard switches in the Spanish network has been quite recent (less than 15 years), this system has been only used for building up

the new switch, but not for replacing an existing switch. However, the methodology for the renewal will be essentially the same.

COMSA practice is to clamp the rails during installation and to weld them just after the first restoration of the switch geometry, once the topographic team has checked that the switch is in its correct position. The line is reopened with a temporary speed restriction, usually between 50 and 80 km, until 200.000 tonnes have passed. Then, the final track geometry restoration can be done.

### 2.7.5 Swedish practice (Banverket/Trafikverket)

The most common method for S&C renewal in Sweden is the pre-assembled S&C method. In this case switch components are transported by trackside access road, the switch is pre-assembled at the vicinity of the works and installation is carried out by means of a railway crane (such as the Kirow crane).



Figure 2.15 - Installation of a switch using the Kirow crane (source: Balfour Beatty).

The number of switches replaced each year in Sweden is about 40. There are not big differences between the activities done in a replacement of a switch in a conventional line and in a high speed line. The activities are mainly the same, however different track closure times apply.

Modular switch is not a common method in Sweden, however, as stated in INNOTRACK project, Trafikverket is planning to start using the “modular switch” to speed up replacement and commissioning of components using computerised self-testing.

The Trafikverket practice is to always replace the complete layer of ballast (which usually has a thickness of 30 cm). The welding of the 12 or 16 welds (depending on how the switch is divided) is done by 2 workers for 2-3 days, depending on track closing times.

After the renewal of the switch there is a speed limitation of 70 km/h, which is applied until 100.000 tonnes have passed by (usually 3 days in a normal line). One or two weeks after the renewal, a second tamping is done to bring the switch into its final position.

### 2.7.6 Czech practice (Skanska)

Every year, around 200 or 300 switches are replaced in Czech Republic. The most common method employed in Czech Republic is the pre-assembled S&C method (95% for mainline tracks). And the

installation is usually done by either DESEC crane-beam system or railway cranes (EDK 300/5 and Kirow crane). If national standards allow it, the renewal is often done with rail-road excavators given that even though it involves usually more labour, is the cheapest practice as far as Eastern Europe is concerned.



**Figure 2.16 - Replacement of a switch using Desec system (source: Skanska).**

At the moment, tilting wagons are not used in Czech Republic, and as a consequence, the modular concept cannot be fully implemented. Notwithstanding this, in some cases a partial modular switch method is used in combination with the pre-assembled method.

If clearance of the line permits it, some of the switch panels can be transported with flatbed wagons directly from the factory. However, there are other switch panels, such as the crossing panel, that must be pre-assembled in the lineside and later transported to the site by means of railway cranes.

The combination of pre-assembled and modular methods permits to reduce the need of space near the worksite for the assembly of the switch and to increase the output of the renewal. However the feasibility of using the flatbed wagons to transport switch panels strongly depends on the dimensions of the panels and the loading gauge of the line.

Furthermore, when the switch is situated in a secondary line, piecemeal renewal is also a common practice, given that it is the cheapest solution. Only the worn-out parts are replaced and they are either refurbished in the workshop and re-installed or replaced by new parts. For partial replacement of S&C the excavators can be used as it is the most economical method for these works.

In what regards to the handing of the switch during transport and installation, there is a Czech standard (SZDC S3/1) that regulates how the switch should be supported during transport (minimum number of handling points, location of the handling points, etc.) in order to minimize deformations of the switch panels. The norm also defines storage conditions of the switch, such as that the maximum number of levels of storage is three.

Usually, after the installation of the switch, a speed limitation is imposed, which usually last for a week.



### 2.7.7 Hungarian practice (MAV)

The majority of the replacement of switches and crossings in Hungary is done using the pre-assembled method. One method of installation of the switch employed by MAV is the UWG system. The UWG system is used to remove the old S&C and to install the new one, as shown in the figures below.



Figure 2.17 - Replacement of a switch using Geismar UWG system (source MAV)

If time is not a big constraint, the preferred solution is to assemble the new switch on the spot. Before assembling the new switch, the old switch is stripped in situ and it is removed in pieces.

Moreover, as stated by Skanska, piecemeal renewal is also a common practice in Hungary in lines with low traffic. It usually refers to the replacement of half switch, the crossing, the wing or guide rails, sleepers or ballast. Although in some cases this is considered maintenance and not renewal.

The Hungarian network contains about 13000 turnouts. Around 70% of the switches in Hungary are made of wooden sleepers and the most common switches have a total length between 30 and 55 m.

The renewal of common switch with wooden sleepers (such as the 54 XIII with 28 m of length) may include or not the renewal of the ballast layer. Nevertheless, for high standard switches such as 54 800, that uses concrete sleepers, the renewal of the ballast layer is mandatory. This results in different track closure times for different types of switches.

In most cases, the current practice is to impose a temporary speed restriction of 60 km/h after installation for two days. Then, the allowed speed is increased in steps of 40 km/h every 24 hours.

### 2.7.8 Turkish practice (TCDD)

There are about 7600 switches in the Turkish network, which are replaced at a rate of 200-300 per year. About one third of the switches have been replaced during the last 10 years.

In Turkey, the common practice is the pre-assembly of the switches in the vicinity of the worksite and the installation by road cranes or excavators. The cranes that are usually employed are road cranes that are placed on the side of the track and that are able to lift the switch panels. Depending on the type of the switch and the location of the cranes, it would be necessary to use one or two cranes to lift one switch panel.

In cases where the access of the cranes by road is not possible, rail-road excavators or the crane-beam of Vaiacar are used.

The renewal time of a switch depends on the type of sleepers used in the switch. The renewal of switches with wooden sleepers usually takes two or three hours less than switches with concrete sleepers.

To avoid speed limitations after the installation of the switches, the Dynamic Track Stabiliser is used, which equals the effect of 50.000-75.000 tonnes of traffic.

TCDD owns four tilting wagons that are used to transport switches (about 27.7 m of length) in two parts. The usage of modular concept of switch replacement is about 1% in Turkey. The availability of the wagons and the distance between the factory of TCDD in Ankara and the worksite led to this low use of the method.

Recently, TCDD has constructed a bigger tilting wagon (28 m-long) that is able to transport the 1:9 190 switches as one single panel. The tilting wagon is currently under testing for validation.



Figure 2.18 - TCDD tilting wagon for switch panel transport (source: TCDD).

### 2.7.9 British practice (Network Rail)

Network rail renews about 340 switches per year. The majority of S&C units and half-sets currently used in renewals of Network Rail infrastructure are manufactured off-site and then assembled for quality purposes at the site of the manufacture, prior to dismantling and re-assembling at the site. Transport of S&C components to site is undertaken by rail or road. Conventional S&C renewal usually requires large areas adjacent to the renewal site for assembly of S&C, which, if the land is not owned by the IM, can inconvenience the landowners and introduce the need for the IM to negotiate with them to gain access to use the land.

The work activities undertaken to plan and undertake S&C renewals vary according to the speed and type of switch, and the geographic location.

During the last decade, Network Rail has been improving its switch renewal method in order to increase outputs and reduce costs. These improvements have come, in part, from the use of the modular concept.

The British rail network has a particularity that hindered during years the development of the modular switch concept, and that is its constricted loading gauge. UK gauge W6 (maximum width of 3.7 m) is much reduced in comparison to UIC gauge G2 (4.4 m), and this made difficult the transport of all switch panels.

To overcome this difficulty two measures were required. On one hand, the design of the switches was modified. Previous long bearers of the switch were segmented (split bearers) to allow transport on the narrow W6A gauge. And on the other hand, tailored tilting wagons were manufactured.

A part from this, NR has also developed a load fixing and handling system to make easier, quicker and safer the loading and unloading of the panel.

Moreover, additional savings of time are achieved by using a specialized machine for ballast removal, which is known as automated ballast collector, and by reducing the time for commissioning the switch.

All these improvements resulted in a drastic reduction of the total renewal time. According to the article written by NR in the International Rail Journal in 2007, the use of modular S&C would allow NR to reduce the average track possession time for installing a traditional crossover from 52 hours to 21 hours in a weekend possession or a 4x8 hours night possessions over a weekend or mid-week. For a single turnout, NR aimed at carrying the renewal in only 8 hours.

According to InnoTrack project, in 2014 Network Rail would replace 75% of the switches using the modular concept. In 2008, NR ordered 26 tilting wagons that were delivered during 2009 and 2010. At the end of 2010, more than 64 switches had been replaced using the tilting wagons.

In what regards to other issues of the renewal, it should be said that NR recommends carrying out the maximum number of welds during track possession (always complying with the minimal requirements). Otherwise the joints are clamped, and welded later.

After the installation of the switch, a speed limitation of 80 km/h is usually fixed for 14 days. Next to this period of speed limitation, the remaining welds are executed and the geometry of the switch is brought to its final position.

## **2.8 Sleeper spacing and sleeper solution**

For new designs of railways lines, solutions for selecting sleepers will be optimized if will be considered the following requirements:

- The sleeper should be capable of resisting vibrations and shocks caused by the passage of fast moving trains.
- Initial investment costs and maintenance cost of the sleepers should be minimum.
- The sleeper unit should have moderate weight for convenient handle.
- The fastenings solution for sleeper should be designed such it is possible to fix and remove the rails easily.
- The sleeper should have anti-sabotage and anti-theft features.
- The sleeper should have sufficient bearing area so that the ballast under it is not crushed.

- The sleeper should be such that it is possible to maintain and adjust the gauge.
- The material of the sleeper and its design should be such that it does not break or get damaged during packing.

### 2.8.1 Sleeper density and spacing of sleepers

Sleeper density is the number of sleepers per rail length. It is specified as  $M + x$  or  $N + x$ .

$M$ ,  $N$  - length of the rail in meters;  $x$  is a number related to factors such as: axle load and speed, type and section of rails, type and strength of the sleepers, type of ballast and depth of ballast cushion, nature of formation.

If the sleeper density is  $M + 7$  on a broad gauge route and the length of the rail is 13 m, it implies that  $13 + 7 = 20$  sleepers will be used per rail length of the track on that route. The number of sleepers in a track can also be specified by indicating the number of sleepers per km of the track, for example, 1540 sleepers/km. This specification becomes more relevant particularly in cases where rails are welded and the length of the rail does not have much bearing on the number of sleepers required. This system of specifying the number of sleepers per km exists in many countries.

The spacing of sleepers is fixed depending upon the sleeper density. Spacing is not kept uniform throughout the rail length. It is closer near the joints because of the weakness of the joints and impact of moving loads on them. There is, however, a limitation to the close spacing of the sleepers, as enough space is required for working the beaters that are used to pack the joint sleepers, see Figure 2.19.

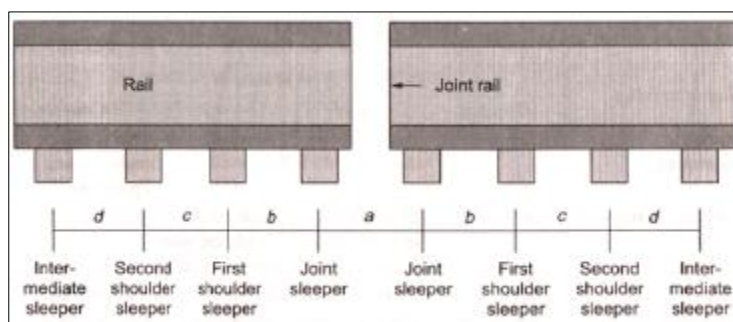

Figure 2.19 - Spacing of sleepers on a fish-plated track

Nowadays sleeper density is also indicated in terms of the number of sleepers/km.

### 2.8.2 Concrete sleepers solution

Concrete sleepers are used in most modern railway lines. Its qualities make them the optimal solution for high-speed trains but also for high capacity of railway transportation. For designs of new railway lines, it is recommended to use concrete sleepers.

The evolution of concrete sleepers has been mainly due to economic considerations coupled with the elements of changing traffic pattern.

Characteristics	Type of sleeper			
	Wooden	Steel	CI	Concrete
Service life (years)	12 - 15	40 - 50	40 - 50	50 - 60
Handling	Manual handling; no damage to sleeper while handling	Manual handling; no damage to sleeper while handling	Manual handling; liable to break by rough handling	No manual handling; gets damaged by rough handling
Type of maintenance	Manual or mechanized	Manual or mechanized	Manual	Mechanized only
Cost of maintenance	High	Medium	Medium	Low

**Table 2.3 - Comparison of different types of sleepers. (9)**

### 2.8.3 Concrete sleepers advantages:

- Concrete sleepers are suited for modern methods of track maintenance and mechanical maintenance, which have their own advantages.
- This type of sleepers are heavy and for this reason have more strength and stability to the track and are properly to be used for long welded track due to their great resistance to buckling of the track.
- Concrete sleepers can be used in track-circuited areas, as they are poor conductors of electricity.
- Concrete sleepers with elastic fastenings allow a track to maintain better gauge, cross level, and alignment. They also retain packing very well.
- They are not inflammable and are not subjected to damage by pests or corrosion under normal circumstances.
- This type of sleepers can generally be mass produced using local resources.
- Concrete sleepers have a very long lifespan, around 40-50 years. As such rail and sleeper renewals can be matched, which is a major economic advantage.

### 2.8.4 Concrete sleepers disadvantages:

- For handling they should be used mechanical methods, which means considerable initial costs. Concrete sleepers weigh about 215 to 270 kg. The mechanical handling of concrete sleepers is desirable for safety purposes.
- Concrete sleepers are not suitable for beater packing.
- Handling and laying concrete sleepers is difficult due to their heavy weight.
- They are heavily damaged at the time of derailment.
- They should preferably be maintained by heavy “on track” tampers.

### 2.8.5 Design considerations of concrete sleepers

Two different concepts are being adopted by German and French engineers in designing the section of a concrete sleeper. The Germans, having adopted a beam type sleeper, consider the sleeper as a rigid, stiff, and continuous beam supported on a firm and unyielding bed. The French version consider the sleeper as two separate blocks connected by a tie bar and resting on a resilient ballast bed. The former design is based on static loading, while the latter theory caters for a slightly differential settlement of ballast support. As the calculations based on the latter theory are quite

complicated and difficult, the sleeper design based on this concept has been evolved mostly on an empirical basis.

In the design of concrete sleepers should be considered factors like: forces acting on a sleeper; effects of the geometric form including shape, size, and weight; effect of the characteristics of fastenings used.

Manual handling of concrete sleepers is difficult, and may damage the sleeper as well. In exceptional cases, however, manual handling, including manual laying of concrete sleepers, is possible after taking adequate precautions.

**Conditions and locations where concrete sleepers could be used** - Concrete sleepers, because of their heavy weight and rigidity of structure, are not suited for any type of formations, fish-plated joints, and places where uniform packing cannot be achieved. Concrete sleepers are normally placed on those locations where long welded rail are possible. Fish-plated joints on concrete sleeper tracks, where unavoidable, should have wooden sleepers at joints. These sleepers should not be laid at the following locations: new formation in banks unless specially compacted and formations with stability problems; on rock cuttings, except where a minimum depth of 300 mm of ballast cushion has been provided; un-ballasted lines in yards; curves of radius less than 500 m; near ash pits and other locations where drivers habitually drop ash; fish-plated tracks.

**Maintenance of concrete sleepers** – For maintenance of concrete sleepers should be taken in consideration next issues:

- Mechanical equipment should be used for laying and maintaining concrete sleepers as far as possible.
- Concrete sleepers should be compacted well and uniformly to give a good riding surface. Centre binding of mono-block concrete sleepers should be avoided.
- Ends of the concrete sleepers should be periodically painted with anticorrosive paint to prevent corrosion of the exposed ends of pre stressing wires. In the case of two-block sleepers, the tie bars should be examined at least once every year, and if any sign of corrosion is noticed, the affected portion should be painted with adequate paint.
- Wherever casual renewal of concrete sleepers is to be done, the normal precautions for tracks should be taken.
- Frequently inspections should be done to ensure that no creep occurs in any portion of the concrete sleeper track or there is no excessive movement near the switch expansion joint (SEJ).
- Whenever it is found that the rubber pads have developed a permanent set, these should be replaced by new ones. It must be ensured that the rubber pads are in their correct positions. Such examinations can be done at the time of de-stressing.
- One of the biggest problems regarding the maintenance of a concrete sleeper track is that the elastic rail clips get seized with malleable cast iron inserts not only during regular maintenance, but also during de-stressing.
- Adequate care should be exercised when driving the clip at the time of installation to prevent damage. Nylon or composite insulating liners used with Pandrol clips should be examined periodically for signs of cracking and breakage.

### 2.8.6 Concrete sleepers for heavier axle load

The existing concrete sleepers, which was designed, by example, for 22.5 tons axle load, has been in service since three decades and has given good service.

To keep increasing freight traffic is to by allowing higher axle load on existing track; this will be more important if will be adopted typology like Dedicated Freight Corridor.

Dedicated freight corridor has been planned for 30 tonnes axle load operation and feeder routes from existing network are planned to carry 25 tonnes axle load. Therefore, 25 tonnes and 30 tones axle load will coexist and these are railways economic requirements for return on.

A detailed study has been carried out for examining the feasibility of the existing concrete sleepers for 25 and 30 tones axle loads. The results of the study are as follows: 25 tones axle load can be run on existing concrete sleepers placed to a density of 1660/km and higher; a slight modification of existing design with initial pre-stress level as 75 % of breaking load can also be tried for 25 tonnes axle load operation; For 30 tonnes axle load operations, new sleepers design should be used.

## 2.9 Ballast and sub-structure.

The technical concept of a railway track consisting of ballast, sleepers, and rails is very old and has stood the test of time. Such a system is simple and can be rapidly extended, renewed, or dismantled. The general problem that occurs with ballasted tracks is that the ballast under the pressure exerted by the load caused geometrical unevenness and clogging of the ballast bed by fine particles. Therefore, regular maintenance is needed to restore track alignment.

The experience in Germany and other countries has been that the conventional track may be used for speeds of up to 250 km/h but not beyond that. For higher speeds, the conventional ballasted track are not feasible and adoption a new solution they required.

There are now a range of modern track forms using a concrete base. They are generally used also, in special locations such as tunnels or bridges where a rigid base is required to ensure track stability in relation to the surrounding structures. This type of track is usually called "slab track" or "non-ballasted" track.

In a ballast less track, the rails are directly fastened to the concrete slab using elastic fastenings. A ballast less track is expensive but is likely to require little or no maintenance during its lifetime.

Earthed must be strictly controlled otherwise serious and expensive problems could occur. Some slab track systems have the sleepers resting on rubber or similar pads so that they become "floating slab track". Floating track is used as a way of reducing vibration and are used in very densely populated areas.

The earth mat is a steel mesh screen provided on electrified railways to try to keep separated return currents from connecting to utilities pipes and nearby steel structures.

Characteristics	Ballasted track	Ballast less track
Reliability of method	Known and proven method; easily available Technology for maintenance	The technology of construction is still in initial stage: New research is however being done.
Absorption of impact forces	Absorbed by ballast and formation	Elastomeric pads absorb the impact
Maintenance due to correction of track geometry	Packing and levelling the track while using ballast as medium helps in correction of surface geometry	Maintenance of correction of surface geometry not easily possible.

Characteristics	Ballasted track	Ballast less track
Maintenance due to settlement and loss of elastic property of track	The pulverization of ballast and its sinking in the formation makes maintenance difficult	Normally no maintenance required except periodical replacement of elastic components.
Quality of construction	Quality is average but construction defects can be attended by mechanized maintenance	Highly sensitive to construction defects; if constructed properly, the quality is very high.
Resistance to lateral and longitudinal forces	Limited resistance but can be slightly improved by mechanized maintenance.	High resistance to lateral and longitudinal forces.
Construction cost	Average	Higher than ballasted track, sometimes even 3 to 4 times

**Table 2.4 - Comparison of ballasted track and ballast less track**

Although most of the current railway tracks are still of traditional ballasted type, recent applications tend more and more towards slab track. The major advantages of slab track are: low maintenance, high availability, low structure height, and low weight. In addition, recent life cycle studies have shown that from the cost point of view, slab tracks might be very competitive.

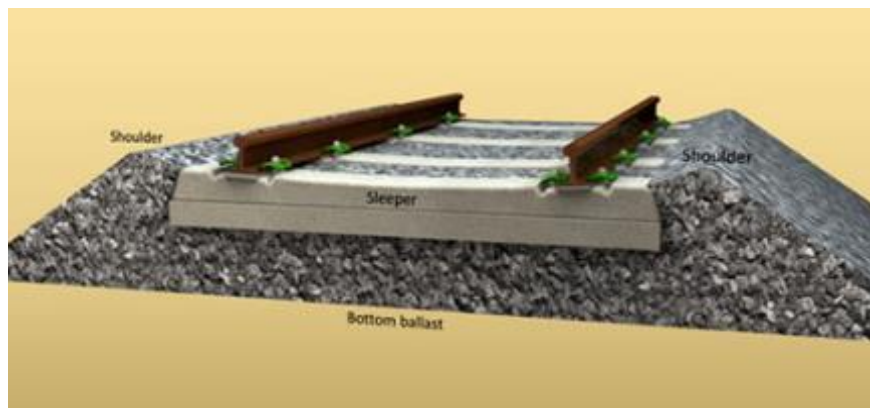

**Figure 2.20 - Traditional track structure (Ballasted Track)<sup>29</sup>**

<sup>29</sup> (Source: <http://www.railsystem.net/track-structure>)



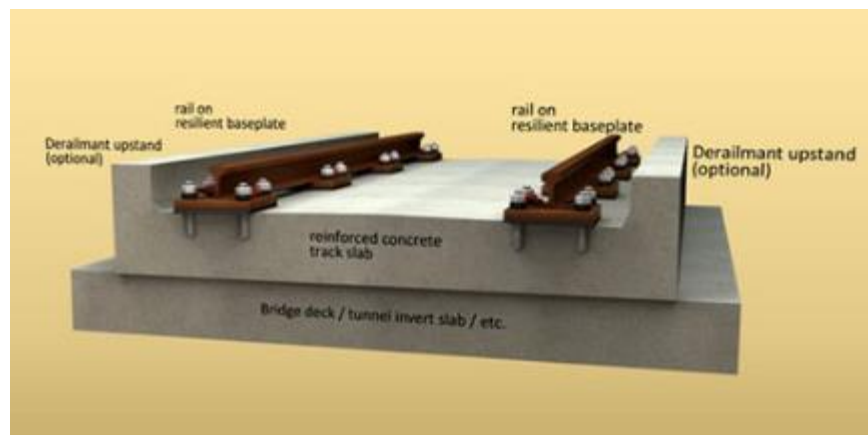

Figure 2.21 - Ballastless track <sup>30</sup>

Despite the known advantages for slab track, the most railways from high speeds category still use conventional ballasted track with pre stressed concrete (PSC) sleepers with elastic fastening; this percent is about 90% of the high-speed track in the world. French TGV marked a record of 525 km per hour on conventional ballasted track; and conventional track is strong enough to bear the stresses of a speed of up to 300 km per hour. But this high performance is kept with high standards of maintenance and higher costs.

Experiences in high-speed operation have revealed that ballasted tracks are more maintenance intensive. In particular, ballast pick-up at speeds of about 275 km/h and more caused by aerodynamic forces/very high wind speeds and air turbulences in the space between the train's underfloor parts and the ballast surface, or dislocation of ice in winter season can cause damage to wheels and rails. The flying ballast stones can destroy parts of the running and braking gear and rapid deterioration of track geometry.

Even the costs for designing and constructing these solution exceeds the cost of ballast tracks solution; experience shows that the maintenance costs, especially in tunnels, are less than the cost of a ballasted track, due to the slower degradation of the geometrical parameters of these tracks. Experience from German railways considers that the increasing cost is between 50% and 75% higher than that for ballasted track.

---

<sup>30</sup> <http://www.railsystem.net/track-structure>



Figure 2.22 – Tunnelling Ballastless Track / Slab Track <sup>31</sup>



Figure 2.23 - Ballastless Track / Slab Track system <sup>32</sup>

Ballastless track is used in France in the underground sections where trains run at a speed of 220 km/h. In Germany a decision has been taken to build sections of high-speed lines (or lines with speeds above 200 km/h) by using ballast less track, except at locations where the trains travel at speeds less than 200 km/h, such as at stations, etc.

According to the design and construction characteristics, slab track systems can be categorized as: discrete rail support (sleepers embedded in concrete, isolated blocks embedded in concrete, sleepers on top of asphalt/concrete layers, prefabricated slabs, direct support on monolithic in situ slabs) and continuous rail support (embedded rails).

---

<sup>31</sup> Source: <http://www.mabatrack.com>

<sup>32</sup> Source: <http://www.instat.gr>

The most popular slab track designs worldwide according to the total length constructed in 2012 are FF Bögl (4391 km), Shinkansen (3044 km), Rheda (2205 km), LVT-Sonneville (1031 km), Züblin (606 km), Stedef (334 km) and Infundo-Edilon (211 km).

The railway systems have to take a strategic decision whether a ballasted deck or a ballast less track has to be adopted for a particular high-speed railway line. However, could be considered that dedicated high-speed corridors for high speeds (250-350 km/h), it may be necessary to use a ballast less track.

## **2.10 Railways Modernization - Trends and Strategies**

### **2.10.1 General considerations**

Main objectives when railways are modernized: allowing heavier trains to run safely and economically at faster speeds; improving productivity; providing better customer service to rail users. This consists of upgrading the track, use of better designed rolling stock, adopting a superior form of traction, better signalling and telecommunication arrangements, using other modern techniques in the operations of a railways system.

Most recently modern strategies for railways modernization:

- Track and infrastructure modernization for high speed trains.
- Railway modernization adopting strategies focused for designing of Dedicated Freight Corridor (DFC) which means for carrying only freight traffic at higher speeds and increased axle loads.

A railway track could be modernizing by incorporating the following features in the track:

- Mechanized maintenance as modernization, in order to ensure better track geometry, facilitate high speeds and smooth travel.
- Use of heavier rail sections (e.g. 52 kg/m, 54 kg/m, 60 kg/m, etc.) and the use of wear - resistant rails for heavily used sections so as to increase the life of the rails.
- Curved switches of 1 in 16 and 1 in 20 type for smoother arrival at yards.
- Pre stressed concrete sleepers (PSC) and elastic fastenings, to provide resilience to the track and ensure the smooth movement of trains at high speeds.
- Introduction of electric traction in order to haul heavier loads at faster speeds.
- Track monitoring using automatic inspection cars with portable accelerometer, to assess the standards of track maintenance and plan for better maintenance.
- Introduction of modern signalling and interlocking systems to enable trains to move at high speeds without any risks.
- Setting up of a management information system for monitoring and moving freight traffic in order to avoid idle time and increase productivity
- Computerization of the train ticket reservation system to avoid human error and provide better customer service for reservation of tickets.
- Use of computers and other modern management techniques to design and maintain railway assets more efficiently and economically, to ensure efficient human resource development (HRD) to increase productivity, and to provide better customer service

## 2.10.2 Track and infrastructure modernization for high speed trains.

The high-speed rail ground transportation (HSGT) system is a concept developed to meet the challenges of the increasing demands of passenger transportation and recover the share of traffic from road and other modes of transport. The International Union of Railways (UIC) defines a high-speed train as one that runs at over 250 km/h on dedicated tracks or at over 200 km/h on upgraded conventional tracks. A “high-speed line” is thus a new line designed to permit trains to operate at speeds above 250 km/h throughout the whole journey, or at least over a significant part of the journey. Alternatively, it could also be an upgraded conventional line, suitable for carrying traffic at speeds above 200 km/h.

Experiments and studies related to high-speed trains have revealed that an increase in speed does not necessarily result in a corresponding increase in the deformation and stresses in track components which involves the use of a heavier track structure. The loads, deformations, and stresses in the track components were found to be amplified as a result of the improper movement of vehicles on the track including pitching, rolling, bouncing, etc., which occur when the track is poorly maintained. Therefore, it is possible to operate the same vehicles at a higher speed on a given track structure without additional loads and stresses, but providing higher level of maintenance for track and the railway vehicles. The existing conventional track structure could be considered to be of adequate standard for speeds reaching until 150km/h.

To have railway lines with speeds at least 150km/h, the standard of maintenance needs to be very high, as very close track tolerances will have to be maintained. Maintaining the existing conventional tracks at such tolerance limits may be uneconomical and will be necessitate the adoption of an improved track structure, which can be maintained at closer tolerance limits at a comparatively low cost. The modern track structure, consisting of long-welded rails with concrete sleepers, elastic fastenings, and ballast less tracks may well fulfil this requirement. The cost of this modern track may be comparatively high, but its maintenance will involve limited expenditure.

### 2.10.2.1 Strategies for introducing high-speed trains:

- **Upgrading of existing railway lines.** The existing infrastructure could be upgraded so that the railway line is made suitable for speeds of 200 km/h and above. In this case, well-designed track, proper rolling stock, and appropriate signalling equipment have to be provided. The existing bottlenecks have to be removed, particularly for track geometry.
- **Designing and construction of dedicated high-speed corridors.** For this purpose, high-tech infrastructure, after laying down the desired standards, will have to be adopted for smooth, efficient and safe operation at designed speeds of 250 km/h and above.

### 2.10.2.2 High Speed Railways in the world

Construction of the first section of high-speed rail (HSR) was conducted in Japan in 1959; "Bullet Train" (Tokaido Shinkansen section) was introduced in October 1964, reaching speeds of 210 km/h. Modernization of railways by building high-speed railway was introduced in Europe in the 1980s and today's high-speed trains operate on more than 18,000 km of track in the world's most advanced railways networks, reaching speeds of 250 km/h to 350 km/h. A high-speed rail line requires adequate infrastructure, new rolling stock, advanced signalling concepts along with other ancillary facilities.

The approximately length of high-speed railway lines in various countries in the world operating at a speed exceeding 250 km per hour is given in next table.

Country	Length of high-	Details of important fast trains
Japan	2678	'NOZOMI': Max. speed limit 300 km/h
France	1893	'TGV': Max. speed 320 km/h
Germany	1300	'ICE': Max. speed 300 km/h
Spain	1687	'AVE': Max. speed 300 km/h
China	3120	High-speed C Class: Max. speed 250 km/h
Belgium	830	Thayls: Max. speed 300 km/h
Italy	890	Eurostar: Max. speed 250 km/h
USA	360	Acela Express: Max. speed 250 km/h
South Korea	412	KTX: Max. speed 300 km/h
Taiwan	245	Chiayi: Max. speed 300 km/h

**Table 2.5 - Length of most important high-speed railway lines in the world operating**

The French Railways holds the world train speed record of 574.8 km per hour, which was set in April 2007. Recently, a Japanese magnetic levitation (Maglev) train achieved a speed of 581 km per hour in trials.

### 2.10.2.3 Infrastructure Track Structure for High-Speed Routes

Will be presented important considerations for designing new high speed lines.

For high-speed routes, 60 kg rails are adopted by the railways world over. Standard length of 25 m in Japan, 54 m and 62 m in Germany, and 108 m in France has been utilized. Continuous-welded rail (CWR) is used to improve the ride quality and to reduce noise and vibrations.

Pre-stressed concrete (PSC) sleepers have been a better choice as they have a long life of 50 to 60 years and very low maintenance.

Double elastic rail fastenings are necessary for the concrete sleeper track. Rubber pads are used as cushioning material between the rail and sleepers fastened for distribution of vertical load and for dampening the vibrations.

Component	SNCF – French Railways	German Railways	Japanese Railways
Gauge	1435 mm	1435 mm	1435 mm
Rails	UIC 54 and 60 kg	UIC 60 kg	UIC 60kg
Rail cant	1:40	1:40	1:40
Sleeper	Concrete/ wooden	PSC/polyurethane foam/ glass fibre	PSC/ polyurethane foam/ glass fibre

Component	SNCF – French Railways	German Railways	Japanese Railways
Sleeper density	1666	1724	1724
Fastenings	TGVNabla/ ICE Vossloh	Leaf spring/ wire spring	Leaf springs/ ICE Vossloh

**Table 2.6 -Track structure for high-speed railways in the world**

Flat curves are generally adopted on a high-speed track. Flat curves become necessary in view of the restriction on maximum values of cant deficiency and cant excess along with the maximum speed of operation. The minimum radius of curvature for high-speed lines generally varies from 4000 m to 7000 m for a standard gauge.

Country	France		Germany		Spain		Belgium
	300	350	300	350	300	350	300
Min R of curvature (m)	4000	6250	3350	5120	4000	6500	4800
Max. cant (mm)	180	180	170	170	150	150	150
Cant deficiency (mm)	85	85	130	112	100	65	100
Max. cant gradient	35	35	40	40	12.5	25	15-21
Min. vertical radius (m)	16000	21000	14000	20000	24000	25000	20000
Transition curve length (m)	300	350	408	476	360	460	420

**Table 2.7 - Geometric parameters of the track for various high-speed railway on world railways.**

As general rule, level crossing is not suitable for high-speed train operation and therefore, need to be planned either road overbridges or road under bridges. But in some circumstances, level crossings may be required. Then it must be used sophisticated arrangement of interlocking for the signals of the train and will be helpful to use of video camera in critical places.

The trespassing is very risky and thus not at all permitted on high-speed lines. Therefore, the entire high-speed track is to be provided with fencing. From the experience of high-speed lines is known that at very high speeds, track ballast stones sometimes fly off and hit the surroundings. To avoid such incidences also track fencing is required.

#### 2.10.2.4 Tilting Trains for High-Speed Routes

For avoiding the limitation of speed on tight curves but also when there are mixed traffic routes, where it is not possible to cant the track, vehicles with a tilting suspension system can be used. Trains that tilt, can go up to 25% to 40 % faster around curves than conventional trains without upsetting the passengers and this can significantly increase the speed on existing lines. Depending on the curvature and other parameters, the train can tilts on the curve and gives additional super elevation to the passengers and thus them experience less cant deficiency and more comfort. With tilting trains, cant deficiency of up to 275 mm is permitted on a standard gauge.

### 2.10.3 Dedicated Freight Railway Corridor

In order to meet the increasing demand of freight traffic, in countries with advanced railway networks is planning to have specially dedicated double lines to carry the increased freight traffic with higher axle load. This concept is defined as Dedicated Freight Corridor (DFC). DFC has designed for new lines to have axle loads of 30 tonnes and for the current lines to increase loading up to 25 tonnes axle load, obvious with improvements even for tracks and wagons.

**Traffic Container** – this is a special and new category of freight transportation and will grows faster than normal traffic. Running of double stack container trains is possible on the lines dedicated for freight because designing and planning of DFC mean also overhead clearances of structures such as road over bridges (ROB), foot over bridges (FOB), and tunnels; also should be taken in consideration the aspects of electrification of the lines, as major improvement of any railway line. For heavier traffic, electrification of routes proves to be a more economical solution in addition to an overall reduction in the consumption of energy versus using fossil fuels.

Most of the existing wagons have to be improved by having lighter steel alloys to enhance the carrying capacity of wagons for a given axle load.

#### 2.10.3.1 Advantages of Dedicated Freight Corridor (DFC)

The concept of DFCs will create advantages for network railway where is applied, through enhancing capacity and mobility of goods transportation but also decongesting passengers transportation.

Moving trains for freight transporting is done quite slowly, with speeds between 75 km/h - 100 km/h. This speed does not fall into the category of speed for passenger trains running normally between 100 km/h - 150 km/h. In addition, trains ranging from DFC category, moving slowly, will not have to wait to give priority to passenger trains that are faster. This will improve the average speed for passenger trains as well as freight trains which will increase their carrying capacity.

Axle load will be higher for optimum operation of DFCs, so are necessary improvements of wagons structure to enhance carrying more goods.

Since there will complete grade separation, the passenger corridors could also run tilt body passenger trains up to speeds of 200 km/h, by suitably fencing the existing tracks and providing proper signalling.

Since running rails are separate, the passenger trains will have possibility to run faster, at higher speeds of up to 200 km / h; for this speed, corresponding pieces of fencing and provision of appropriate signalling should be designed and installed.

Resuming, the main advantages are following:

- To relieve existing rail corridor for additional passenger traffic.
- The possibility to create infrastructure capable of carrying a high level of goods and therefore will increase market share loads.
- To speed up freight train operations, achieving higher productivity.
- Axle loads increasing, that means better track loading density and improved pay load ratio.
- Reducing cost of transportation and greater customer satisfaction.

### 2.10.3.2 Improvements recommendations for designing DFC

#### Track line structure:

- Use of concrete sleepers on the entire route including points and crossings.
- Use of thick web tongue rails for switches of points and crossings to ensure smooth running of trains and minimize maintenance costs.
- Long welded rails on the entire route to ensure noiseless travel and minimum maintenance.

#### Bridges and viaducts:

- Pre-casting of pre-stressed concrete bridge girders followed by launching.
- Adoption of hollow reinforced concrete piers for tall viaducts constructed by slips forming.
- Reinforced concrete framed configurations for viaducts.
- Bridges are concrete decks and ballasted track in order to maintain uniformity of track structure and reduce maintenance costs.

#### Tunnels:

- Forced ventilation of long tunnels to ensure desirable environment inside.
- Ballast less track in long tunnels to ensure practically maintenance-free track and safe operation of trains.

#### Signalling and telecommunications:

- Should be installed optic fibre communication links along the alignment to facilitate fast communication and to improve the working efficiency of the system during the operational phase.
- Will be provided panel interlocking and four-aspect colour light signalling to enhance operational efficiency.
- Computer network along the route to facilitate efficient train movements

#### Regional economic aspects:

- Economic enhancing, including increased employment resulting from better transport facilities
- Regions with natural resources will have possibility to receive new investments in exploitation and extraction of mineral, investments in agricultural regions and educated manpower resources.
- Will increase the industrial investments that depend by efficient transport facilities.

Security for the line should be a concern for security transportation. For these would be used closed-circuit cameras at all major bridges, tunnels, and railway stations; lighting is provided on all major bridges and inside tunnels.

One of the first improvements for better utilisation of DFC's is to increase the axle loads on the routes so have to increase railway capacity by allowing the rolling stock to be loaded to their optimum carrying capacities. (9)



### 3. Technologies and practice used in partners' countries

#### 3.1 General observations

In this chapter we will make identification of the used technologies in the partners' countries and in addition we will contribute with detailed data of components and technologies used for the lines included in Task 1.1 into a list with case study I studies cases list data from countries outside the consortium to which we have access.

#### 3.2 Technologies and practice used in United Kingdom

##### 3.2.1 Categories of track lines

Based on the train speed and the tonnage of material passing the track per annum, train lines divided into seven different categories. *Figure 3.1* provides the matrix for different track categories.

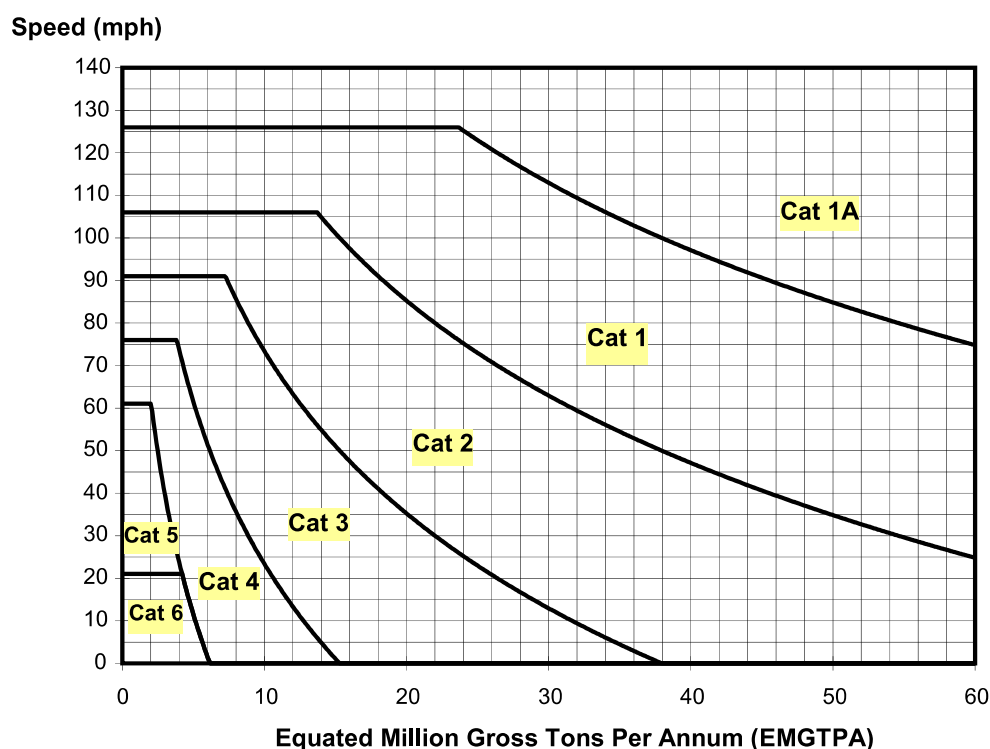

Figure 3.1 -The track category matrix <sup>33</sup>

<sup>33</sup> Ref: NR/L2/TRK/001/mod02

### 3.2.2 Switches and crossings

Table 3.1 provides the different types of switches, crossing, bearers and ballast depths used in different track categories.

Track Category	Design of S&C <sup>a,b</sup>	Bearers <sup>c,d</sup>	Minimum ballast depths <sup>e</sup> mm	Extent of associated Plain line <sup>f,g</sup>
1A & 1	New Shallow Depth Vertical for switches CV to FV. <sup>k</sup> New NR60 for fittings with SG, G & H switches	Concrete	300, consolidated in 150 mm layers. Reballasting of all welded concrete bearer fittings permitted	18 m off toes, 36 m off last long bearer, plus ballast ramps
2	New Shallow Depth Vertical for switches CV to FV. <sup>k</sup> New NR60 for fittings with SG, G & H switches	Concrete <sup>h</sup>	300, consolidated in 150 mm layers. Reballasting of all welded concrete bearer fittings permitted	18 m off toes, 27 m off last long bearer, plus ballast ramps
3	New Shallow Depth Vertical <sup>k</sup>	Concrete <sup>h</sup>	300, consolidated in 150 mm layers. Reballasting of all welded concrete bearer fittings permitted	18 m plus ramps either side of new S&C
4	New Shallow Depth Vertical <sup>k</sup>	Concrete <sup>h</sup>	300, consolidated in 150mm layers Reballasting of concrete and timber permitted	18 m plus ramps either side of new S&C
5 & 6 Running Lines	Serviceable or new Shallow Depth Vertical, part fabricated crossings <sup>j</sup> <sup>m</sup>	Concrete, or steel <sup>h,i</sup>	250, consolidated in one layer Reballasting of concrete and timber permitted	9 m plus ramps either side of new S&C
5 & 6 Sidings	Serviceable or new Vertical, part fabricated crossings <sup>j,m</sup>	Concrete, hardwood or steel <sup>h,i</sup>	200, consolidated in one layer. Reballasting of concrete and timber permitted	

Table 3.1 -Selection of S&C components <sup>34</sup>

1. CWR-compatible S&C elements have to be welded and stressed. Where welding is not possible, and in different type of S&C, fish-bolt holes will be implemented in accordance with RT/SE/S/050. Crossing compatible with CWR and no welded-on leg-ends have to attach to the adjacent rails with tight joints.
2. Design and configuration:
  - Line speed more than 90 mph and cant reaches 90 mm, the permitted S&C is NR60 (C to H) on concrete bearers with type E rail check at high speed.
  - Maximum line speed through short switches and complex S&C is provided in NR/L2/TRK/2049.

<sup>34</sup> Ref: NR/L2/TRK/2102

3. Hollow bearers have to be used inside switch panels depend on point operating mechanism.
4. Soffit level of the bearer compare to the rail level must be consistent with the design within  $\pm 10\text{mm}$ .
5. Blanketing and formation treatment may require for depths below bearer.
6. Ballast depths must be consolidated in two layers.
7. Minimum length of ramp (m) is depend on the train speed (mph) and ballast depth if it is higher than the minimum.
8. Where is impossible to use concrete bearers will be used hardwood timbers.
9. Serviceable RT60 or NR60 S&C can be used if available.
10. Steel bearer S&C (excluding hollow steel bearers for Point Operating Mechanisms) cannot be used in areas of 3rd rail DC electrification or in Track Circuited areas.
11. BR109 inclined or Bullhead may be used when renewing individual leads on a like for like basis within existing sidings, the material type shall be commensurate with adjacent track.

### 3.2.3 Choice of rail joints

Table 3.2 provides the list of different joints used in different track categories.

Track Category	Insulated joint type
1A, 1 and 2	6-hole shop assembled glued insulated joint
3, 4, 5, and 6	6-hole shop assembled glued insulated joint 4-hole shop assembled glued insulated joint 6-hole dry insulated joint
<p><b>Note:</b> In the event of an IRJ failure necessitating the changing of the fishplates in track Category 1A, 1 or 2 line which is being inspected at extended intervals under the arrangements of this appendix, a 6-hole dry insulated joint may be formed as a temporary arrangement but it shall be replaced with a 6-hole shop assembled glued insulated joint within 13 weeks or inspection to the frequency in Figure 1 shall resume.</p>	

Table 3.2 - IRJs in the CWR length <sup>35</sup>

<sup>35</sup> Ref: NR/L2/TRK/001/mod02

Baseplate Type	Rail Section	Insulators		Rail Seat Pad Type				Clips		Notes
		Type	Cat No. 57/-	Above 90 m.p.h.		90 m.p.h. and below		Type	Cat. No. 57/-	
				INST.	MTCE.	INST.	MTCE.			
PAN 1, PAN 3	113A / 110A	-	-	3A	3A	3A	3A	PR427A PR427A PR428A PR428A	48245 48242 48244 48249	CP LH LH, CP
	109 / 98	-	-	4C	4C	4C	4C			
PAN 2, PAN 4, PAN 4A, PAN 5	113A / 110A	-	-	Nil	Nil	Nil	Nil	PR401A PR401A PR402A	48239 48253 48243	CP LH
	109/98	-	-	1	1	1	1			
PAN 7, PAN 8, PAN 10, HO PAN	113A / 110A	-	-	Nil	Nil	Nil	Nil	PR401A PR401A PR402A	48239 48253 48243	CP LH
	109/98	-	-	1	1	1	1			
PAN 6, PAN 9, PAN 9J, PAN 11, PAN 12, ASP, V4N	113A / 110A	-	-	3A	3A or 4C	3A	3A or 4C	PR401A PR401A PR402A	48239 48253 48243	CP LH
	109/98	-	-	4C	4C or 5	4C	4C or 5			
V, L PAN 6, PAN M6, PAN L6, LGN, LR6	113A / 110A	-	-	3A	3A	3A	3A	PR401A PR401A PR402A	48239 48253 48243	CP LH
CV	113A / 110A	-	-	3B	3B	3B	3B			
RCV, Switch Heel Baseplates & Crossing Baseplates	113A / 110A	-	-	3C	3C	3C	3C	PR401A PR401A PR402A	48239 48253 48243	Cut pads required from strip
MV	113A / 110A	GRN (Blue) GRN (White)	48027 48436	3A	3A	3A	3A			Type of insulator used is dependent upon the side Gall of the rail. Blue - Gall Severe White - Gall Slight
ASP, VASP	113A / 110A	-	-	3D	3D	3D	3D	PR401A PR402A	48239 48253	LH
	109/98	-	-	4C	4C	4C	4C			
3rd Rail Insulators types 140, 120, 100	150	-	-	18	18	18	18	-	-	
Slab Track using 10 mm thick strip pad	113A / 110A	-	-	16 or 17	16 or 17	16 or 17	16 or 17	PR401A PR401A PR402A e1809	48239 48253 48243 48255	CP LH
VB	113A / 110A	-	-	2 x 3A	2 x 3A	2 x 3A	2 x 3A	PR401A PR401A PR402A PR402A	48239 48253 48243 48234	CP LH LH, CP
VC	113A / 110A	-	-	1 x 3A 1 x 3B	1 x 3A 1 x 3B	1 x 3A 1 x 3B	1 x 3A 1 x 3B			
VD	113A / 110A	-	-	2 x 3B	2 x 3B	2 x 3B	2 x 3B			
NRS1, NRS2	CEN56E1	10274 field 10275 gauge	48082 48081	25 (or 21)	25 (or 21)	25 (or 21)	25 (or 21)	e2007 e2007	48248 48045	CP
NRS1, NRS2	CEN60E1/E2	5720 Both (or 4452 both)	48060 48027	25 (or 21)	25 (or 21)	25 (or 21)	25 (or 21)	e2007 e2007	48248 48045	CP

**Abbreviations used throughout:**

GRN: Glass Reinforced Nylon  
EVA: Ethyl Vinyl Acetate  
RBC: Rubber Bonded Cork

INST: Installation with all new materials  
MTCE: Maintenance or serviceable materials  
CP: Corrosion Protection (previously 'Sheradised')

FC: FASTCLIP  
eP: e-Plus  
LH: Left Handed

Table 3.3 Details of different baseplate, rail sections, insulator, pads and clips <sup>36</sup>

<sup>36</sup> Ref: Track Design Handbook NR/L2/TRK/2049

Code	Rail Seat Pad Type	Cat no. 57/-	Code	Rail Seat Pad Type	Cat no. 57/-
1	2.5 mm Lipped EVA (220 X 140)	48476	12	10.5 mm 'H' Rubber (Pandrol)	48028
2	5.5 mm 'H' EVA	48521	13	1.5 mm RBC	48017
3A	5.5 mm Lipped EVA (260 x 140)	48093	14	1.5 mm RBC (Height adjustment)	48730
3B	5.5 mm Lipped EVA (260 x 250)	48178	15	1.5 mm RBC (Height adjustment)	48731
3C	5.5 mm Lipped EVA (260 wide strip)	48449	16	10.5 mm RBC (150 x 2000)	
3D	5.5 mm Lipped EVA (220 x 140)	48094	17	10.5 mm Rubber (150 x 2000)	
4A	7.5 mm Lipped EVA	48095	18	FC16 9.3/8" x 5.7/8" x 3/16" (pad under conductor rail insulator)	49152
4B	7.5 mm 'H' EVA	48086	19	5.5 mm '+' EVA (for SHC)	48493
4C	7.5 mm Lipped EVA (220 x 140)	48089	20	7.5 mm '+' EVA (for SHC)	48499
5	10.5 mm Lipped EVA	48096	21	10.5mm 'H' Rubber (Pandrol 5197)	48088
6	5.5 mm '+' Rubber (for SHC)	48092	22	10.5mm 'H' Rubber (Pandrol 9328)	48293
6A	7.5 mm '+' Rubber (for SHC)	48492	23	10.5mm 'H' Rubber (Pandrol 6650)	48271
7	5.5 mm 'H' Rubber	48091	24	10.5mm 'H' Rubber (Pandrol 8854)	48254
8	7.5 mm 'H' RBC	48267	25	10.5mm 'H' Rubber (Pandrol 7031)	48613
9	7.5 mm 'H' Rubber	48269	26	10.5mm for Vossloh W14 with CEN56E1 Rail	48682
10	10.5 mm 'H' RBC	48029	27	10.5mm for Vossloh W14 with CEN60E1/E2 Rail	48683
11	10.5 mm 'H' Rubber	48268			

Attenuation types: EVA (Ethyl Vinyl Acetate) = Type C, Rubber = Type B, RBC (Rubber Bonded Cork) = Type A.

Table 3.4 rail seat pad type and cat number <sup>37</sup>

<sup>37</sup> Ref: Track Design Handbook NR/L2/TRK/2049

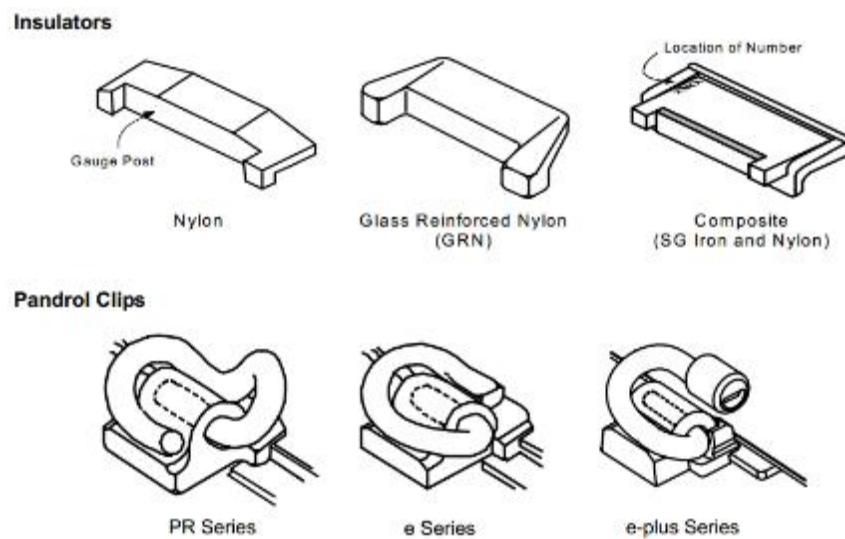

Figure 3.2 drawings of different insulators and clips <sup>38</sup>

### 3.2.4 Choice of rail types

**Premium or normal steel rails** <sup>39</sup> - After a rail life cycle finishes the rail will get replaced by new premium rail at the following priority locations:

- The rail life cycle is less than five years;
- Or the whole life cost can be justified;

All other locations normal R 260 grade rails will be used. Premium steel rails should be installed between points of zero cant to zero cant when applying to the curves. Premium steel rail are only necessary to install on the affected rails with using approved welding process. It is important to produce other track components like IRJs, adjustments switches, and twist rails, crossing leg ends and transition pieces from the same premium steel rail which used in these sites.

**Metallurgy and manufacturing** <sup>40</sup> - Rail to be accepted by the Network Rail should be:

- Capable of being butt welded together (by the Network Rail approved standards)
- Require less efforts needed to find the defects
- Failure criteria can be defined e.g. wear limit

**Rail section and head profile** <sup>41</sup> - Network rail should accept the whole rail section and its head profile to be compatible with existing rail infrastructure and wheel-set profile in use. Older rail sections like 95 RBH can be used in the places with old profile rail still in use or where the fastenings cannot accommodate the new profile rail sections.

<sup>38</sup> Ref: Track Design Handbook NR/L2/TRK/2049

<sup>39</sup> Ref: NR/L2/TRK/001/mod10)

<sup>40</sup> Ref: NR/L2/TRK/2102

<sup>41</sup> Ref: NR/L2/TRK/2102

Rail grade is normally 260, however premium hardened rail steel have to be used where a high rate of side-wear, significant flattening of the low rail or corrugation occurs.

In the location which premium steel rail is used a planned maintenance grinding regime must be considered. In the curves subjected to side-wear the rail grades shall not be mixed.

Note 1 - approved coated rails by Network Rails are available and are recommended to be used in places subjected to corrosion like level crossing or wet tunnels.

Note 2 - BS113A rail and CEN56E1 are considered to be fully interchangeable.

**Rail coating**<sup>42</sup> - Inspection results can prioritise the location which rail coatings could be most beneficial like level crossings, coastal locations and tunnels. When a replacement installation happens using coated rail it should be at locations where:

- Rail life cycle is less than three years
- The whole life cost benefits can be justified

Installation should be by the approved processes by Network Rail standards welding and re-coating.

#### **Rail corrosion**<sup>43</sup>

The period of the inspection for corrosion is every 12 months, unless risk assessment extending the frequency of these inspections. TEF3043 should be used for this assessment, the TME (track maintenance engineer) should consider the history of the site, its environmental and physical factors. Important factors to notice are:

- Rail and fastening conditions on previous inspections
- The period that the rail has been replaced
- If the flange-ways are disposed to silting up
- If the highway close to the track regularly salted
- If electronic corrosion happens in the crossing

Level crossings are particularly susceptible to rail corrosion due to salt from road vehicles. It is necessary to remove a sufficient amount of the road platform at a level crossing to be able to do a detailed inspection and assessment of rail corrosion and allow the measurement of rail depth.

Rail foot and web are most vulnerable to corrosion and need more attention, also as the road platform removed it's possible to inspect the other exposed sub-surface of track components, like sleepers, ballast, rail fastening, rail pads and insulators. However, there are some methods available to measure the rail depth without surface removal.

---

<sup>42</sup> Ref: NR/L2/TRK/001/mod09

<sup>43</sup> Ref: NR/L2/TRK/001/mod09

### 3.2.5 Choice of lubrication <sup>44</sup>

After renewing the rail track, flange lubricators shall be changed as well. If no lubricant exist and the rail is to be renewed, lubricant should be applied to all curves:

- With a radius of 1000 m or less;
- Exhibiting side wear;
- With a history of side wear;
- That have been identified as “at risk” by Engineers due to the introduction of new rolling stock.
- A history of Rolling Contact Fatigue (RCF) (in order to help preserve a satisfactory rail profile);
- A history of noise complaint (Low rail damage = Low rail noise/squeal. Possible low rail friction management required).

In every curve which a check rail is fitted, lubricators shall be fitted as well and commissioned to both check rail rubbing face and the top running rail. All lubricators should be operational two weeks from opening to traffic.

On long or back-to-back reverse curve, a new electric lubricator or more than one conventional one shall be used to have more uniform deposit along all running faces throughout the curve.

### 3.2.6 Choice of inspection frequency <sup>45</sup>

Undertake ultrasonic testing at the frequencies shown in Table 3.5. The maximum permitted timescales between ultrasonic tests are shown in Table 3.6 for pedestrian ultrasonic testing and Table 3.7 for UTU testing (Ultrasonic Test Units – train mounted ultrasonic inspection units).

Activity / Location	Track Category						
	1A	1	2	3	4	5	6
UTU inspection	8 weekly	8 weekly	16 weekly	26 weekly (6 monthly)	26 weekly (6 monthly)	26 weekly (6 monthly)	52 weekly
Visual inspection of: all pre-1976 rail in plain line; all rail in S&C	13 weekly	26 weekly (6 monthly)	52 weekly (Yearly)	104 weekly (2 Yearly)	104 weekly (2 Yearly)	104 weekly (2 Yearly)	104 weekly (2 Yearly)
Visual inspection of: plain line in tunnels	13 weekly	26 weekly (6 monthly)	52 weekly (Yearly)	52 weekly (Yearly)	52 weekly (Yearly)	52 weekly (Yearly)	104 weekly (2 Yearly)
Visual inspection of: adjustment switches (for the presence of lipping [see note 1])	8 weekly	13 weekly	26 weekly (6 monthly)	52 weekly (Yearly)	52 weekly (Yearly)	52 weekly (Yearly)	104 weekly (2 Yearly)
U15 Pedestrian Ultrasonic testing of: • plain line CWR and jointed, • full section rail in S&C [see note 2] and • crossings in S&C.	13 weekly	26 weekly (6 monthly)	52 weekly (Yearly)	104 weekly (2 Yearly)	104 weekly (2 Yearly)	104 weekly (2 Yearly)	104 weekly (2 Yearly)
U15 Pedestrian Ultrasonic testing of all rail in tunnels	8 weekly	13 weekly	26 weekly (6 monthly)	52 weekly (Yearly)	52 weekly (Yearly)	52 weekly (Yearly)	104 weekly (2 Yearly)
U16 or U1 / U2 Pedestrian Ultrasonic testing of: • fishbolt holes in jointed track [see note 3] • any bolt holes or bond hole >15mm diameter • rail joints in CWR (including insulated rail joints)	8 weekly	13 weekly	26 weekly (6 monthly)	52 weekly (Yearly)	52 weekly (Yearly)	52 weekly (Yearly)	104 weekly (2 Yearly)
<b>Notes:</b> 1 see NR/L2/TRK001/mod16 for details of the requirements following visual inspection if lipping is present. 2 to include sections of machined rail which is tested using U15. 3 If the hole is no longer used for fastening purposes (no bolt), testing to this reduced frequency is not necessary.							

<sup>44</sup> Ref: NR/L2/TRK/2102

<sup>45</sup> Ref: NR/L2/TRK/001/mod06



Table 3.5 frequency of visual inspection and ultrasonic testing of rail <sup>46</sup>

Nominal planning interval	Maximum interval between inspections
Twice per week	4 days
Once per week	8 days
Once per 2 weeks	17 days
Once per 4 weeks	35 days
8 weekly	10 weeks
13 weekly	16 weeks
16 weekly	20 weeks
26 weekly	32 weeks
yearly	1 year & 8 weeks
Two yearly	2 years & 16 weeks

Table 3.6 Maximum interval between inspections; visual inspection and pedestrian ultrasonic testing <sup>47</sup>

Track Category	Planned interval	Maximum interval
1A	8 weekly	10 weeks
1	8 weekly	13 weeks
2	16 weekly	26 weeks
3	26 weekly	34 weeks
4	26 weekly	34 weeks
5	26 weekly	34 weeks
6	52 weekly	78 weeks

Table 3.7 Maximum interval between inspections, ultrasonic testing using the UTU <sup>48</sup>

### 3.2.7 S&C lubrication <sup>49</sup>

To have free movement in switches, lubrication frequency is important. Also the slide surfaces of slide chairs or baseplates should be clean and well lubricated. To lubricate all sides of switches, they have to be reversed during the application. As for dry slide chairs no lubrication shall be inserted, any contamination shall be removed from the slide surface, also a check for wear should be carried out to prevent abrasion damage and plastic dry-slide chairs shall not be inserted into train operated points.

<sup>46</sup> Ref: NR/L2/TRK/001/mod06

<sup>47</sup> Ref: NR/L2/TRK/001/mod06

<sup>48</sup> Ref: NR/L2/TRK/001/mod06

<sup>49</sup> Ref: NR/L2/TRK/001/mod05

It's better to use roller baseplates when replacement switches are installed on existing bearers. A survey should be done on both half-sets of switches before fitting to check compatibility of the proposed new arrangement – the survey should include checking

- Existing slide baseplates, like baseplate thickness and length
- The point operating mechanism (by consultation with the Signal Maintenance Engineer)
- Maintaining the required clearance between the stock rail and stretcher bar kicking strap

Unless recommended by the manufacturer, do not lubricate the roller baseplate. Roller baseplates shall not be installed on: Train operated points, like spring points and hydro-pneumatic points; Hand points

### **3.3 Technologies and practice used in the Netherlands**

The railway infrastructure in the Netherlands is one of the most intensively used systems in Europe. The Dutch railway network is approximately 2800 km long and includes 6500 km of tracks, 4700 km of electrified tracks, 8700 switches, 4500 bridges and tunnels, 3000 level crossings, and 380 stations. The system carries more than 1200000 passengers on 6000 trains per day.

The wheel/rail interface has been the focus of a significant number of research projects and improvement measures in the Netherlands over the last 10 years. A preventive gradual grinding strategy has been implemented to remove developing fatigue damage.

In the Netherlands, infrastructure managers and operators of the rolling stock are separated organizations. For reducing the effects of head checks, joint efforts allowed to understand much better the phenomenon and successfully extended the life cycle and reducing damage for both wheels/trains and rails/tracks. From the infrastructure side, a new “anti-head check” rail profile (54E5) was designed. From the rolling stock side, wheel profiles have been optimized based on the new 54E5 profile. This project has led to reduced contact stresses and RCF initiation.

The infrastructure manager of the Dutch network: ProRail, is aware of the importance of a good connection with academia. Currently, ProRail is funding many research projects to gain a better insight of their infrastructure and to increase the cost-effectiveness of their maintenance strategies. Some of the projects focus on the analysis and detection of squats, rolling stock redesign, the role that new types of steel can play, and more effective measures through damage-based maintenance.

### **3.4 Technologies and practice used in Slovenia**

SZ partner contribution for list of case studies are represented by three lines with particular characteristics and covering lines classification, defined as points of interest in NeTIRail project.

Slovenian Railways - Slovenske Železnice (SZ) - is the state railway company of Slovenia, created in 1991 from the Ljubljana division of the former Yugoslav Railways after the breakup of Yugoslavia. Slovenia is a member of the International Union of Railways (UIC). The UIC Country Code for Slovenia is 79.

Slovenian Railways operates 1208 km of standard gauge tracks, 334 km as double track, and reaches all regions of the country. It is well connected to all surrounding countries reflecting the fact that Slovenia used to be part of the Austro-Hungarian Empire and later of Yugoslavia.

Electrification is provided by a 3 kVdc system and covers about 503 km, with further electrification in progress from Pragersko to Hodoš on the Corridor V. The remainder of the former Yugoslavian railroads, that have been electrified operate, with 25 kVac/ 50Hz system, thus trains to Zagreb switch engines at Dobova until dual system engines will be available.

Related to the study categories (busy passenger, low density rural/secondary line, and a freight dominated route) proposed to analyses in the NeTIRail project, next strategies are considered for maintenance activity.

**Busy passenger category lines:**

Active maintenance mode - Maximal inspection works applied. No preventive changing of superstructure. Local faults fixed immediately. Rest works planed according to measurement/ inspections results. Superstructure is usually not a problem, because of light passenger trains. It is smart to prepare inspections of passenger comfort. Objects of substructure have been renewal by plan according to periodical inspections.

**Low density rural/secondary category lines:**

Passive maintenance mode - Maximal inspection works applied. No preventive changing of superstructure. Local faults fixed when occurred. Rest works planed according to measurement/inspections results. Wearing of superstructure is usually not a problem, because of lack of trains. Wooden slippers could be problem because of aging (gauge). Objects of substructure have been renewal by plan according to periodical inspections.

**Freight dominated category lines:**

Preventive maintenance mode - Maximal inspection works applied. Preventive changing of rails (due to wear and number of breaks), fastening, wooden slippers and ballast are used. In case of concrete slippers if gauge is ok, is no exchange. If ballast is clean and in good condition then installation is added only on ballast. Other circumstances exchange the ballast. Objects of substructure have been renewal parallel with maintenance work on superstructure.

## **3.5 Technologies and practice used in Romania**

### **3.5.1 General presentation**

Currently, the Romanian railway network consists of nine main lines, and other secondary lines.

The speed limit for all trains from Romania is 160 km/h, and technical circulation speed is 68, 88 km/h.

The total length of operational railway infrastructure at 31.12.2014 is 19.936,24 km, of which 13.678,93 km are current lines and direct and 6.257,31 km station lines.

From those 19.936,24 km of railway lines, 17.592,04 km belongs to public railway infrastructure and 2.344,20 km belongs to private infrastructure.

From the total of 19.936,24 km of railway lines, 4.818,23 km are non-interoperable lines (3.862, 05 km current lines and direct and 956, 18 km are lines within stations).

On the public railway network there are 18.032 bridges and footbridges with a total length of 227,511, of which 5.092 with metallic superstructure, 12.635 with concrete superstructure, reinforced concrete, pre-stressed concrete or stone masonry, brick and 305 open footbridges.

The number of existing tunnels on running lines is 171, with a length of 67,086 km, of these a number of 108 tunnels are on electrified lines.

Railways infrastructure represents all earthworks, including consolidation, protection, ining (retaining walls, drains, pitching, other works for embankments protection and consolidation, and so on), and of art (bridges, footbridges, tunnels, and so on).

Railway superstructure consists mainly of rails, sleepers, track fastenings and track prism. Also, the railway superstructure includes the points and crossings.

**Track gauge** is the regulated width in a straight line, representing the distance between the inner sides of the two tracks measured at 14 mm below the common tangent plane to the running surface. Normal track gauge is 1435 mm (this is adopted also by the Romanian railways).

### 3.5.2 The rail

Recommended track types to be used in Romania:

- Main current lines and direct from stations in lowland areas with many curves of wide radius and straight lines, with intensive traffic and high running speeds: new rails type UIC 60 or R65 thermally untreated, which is welded to obtain track without joints;
- Main lines, current and direct from stations in hill and mountain areas with few straight lines and curves of small radius, with medium traffic and low running speeds: new rails type S 49, UIC 60 or R 65 thermally treated, which can remain un-welded in curves of small radius or they can be welded to obtain track without joints;
- Current lines and direct from stations of trans-European corridors with maximum running speed up to 200 km/h – new rails UIC 60 or R 65 thermally treated or untreated which are welded to obtain track without joints;
- Secondary current lines and from stations with low traffic and low running speeds: medium-used rails removed from main lines and/or reconditioning type 49, 54, 60, 65.

The rails used on Romanian railways are vignole type and must meet the requirements imposed by regulation in force.

### 3.5.3 Sleepers

Railway sleepers are used depending upon the line category (axle load and maximum running speed) and of rail characteristics (track gauge, rail type and fastening, route):

- Normal timber sleepers for path in curves of small radius, path on ballasted bridges and special sleepers (for bridges and points and crossings).
- Monobloc concrete sleepers for current lines and stations, bridges and points and crossings.

The sleepers chart are according to the type of rail, length of rails, sleeper type, track type (path with and without joints). The distance between sleeper centres varies between 55 and 65 cm. On trans-European corridors distance between sleeper centres is 60 cm.

On CFR network are used concrete sleepers types T 13, TS 13, T 16 and T17. Reinforced concrete sleepers cannot be used in curves, on points and crossings, at level crossing and where embankments are likely to subsidence after putting the line into service.

#### **3.5.4 Fastening systems**

The types of fastening the rails on the sleepers are according to the type of the sleeper: timber or concrete. On the timber sleepers the indirect fastening type K is used.

On pre-stressed concrete sleepers for current lines with  $R \leq 400$  m, for the path on bridges and points and crossings one use indirect fastening type K with rail clips or elastic clips.

On current lines, direct lines from stations, track with or without joints, in a straight line and curves with  $R > 400$  m direct or indirect elastic fastening systems are used.

#### **3.5.5 Crushed stone**

The classic rail sleepers are embedded in a layer of crushed stone (less often screened broken ballast) called track prism.

Dimensions of track prism and track prism materials are according to the intensity of traffic, track destination and type of sleepers.

On European corridors, current main lines and direct crushed stone of class I is used.

#### **3.5.6 Points and crossings**

Points and crossing is a mechanical installation enabling ramification/ level track intersection. The main categories of points and crossings are crossings, group of scissor crossings and turnouts.

The crossing serves at two lines crossing with level track intersection and enables passage from one line to another in both directions.

**Group of scissor crossings** connects two parallel lines, ensuring passage in all directions.

The simplest point and crossing that ensure rail continuity and allow free pass of the wheel flange in the rail intersection point is the turnout.

#### **3.5.7 Railway stations and marshalling yards**

Current line is located between the extreme ramifications points of two neighbouring stations.

The stations are part of the railway network, equipped with special constructions, designed to meet the traffic requirements of goods and passengers or rail operating needs. These buildings are situated along the railway lines in order to create connection points with other transport systems (road, sea, air, through lines), of the national transport system.

Railway stations can be classified according to several criteria, namely:

- for the purpose they serve:
  - passenger, freight or mixed stations, serving the traffic needs;
  - service stations that serve the needs of maintenance (yards, depots, sheds);
- their importance:
  - marshalling yard (between two marshalling yard there is a line section named running section on which are located several intermediate stations or halts);
  - intermediate stations;
  - halts;

### **3.5.8 Level crossings**

At the railway junction with a road or pedestrian crossing, in order to ensure road and pedestrian traffic in safety conditions, level crossings are provided.

The intersection of trans-European corridors with other communication routes (rail, road) must be done at difference of level.

### 3.6 Comparative table for the seven case studies chosen in the NeTIRail Project

Rail Line identification /name	Divača – Koper	Pivka - Ilirska Bistrica	Ljubljana - Kamnik	Bartolomeu - Zarnesti	Kayaş - Sincan	Divriği - Malatya	Malatya – İskenderun
Line Category	Freight dominated route	Low density rural / secondary line	Busy passenger	Low density rural / secondary line	Busy passenger	Low density rural / secondary line	Freight dominated route
<b>Railway Track Gauge:</b>							
Dimension	1435 mm	1435 mm	1435 mm	1435 mm	1435 mm	1435 mm	1435 mm
Types of other gauges, if existing	/	/	/	/	/	/	/
<b>Traction Power:</b>							
Type of traction power (e.g. diesel, electric, diesel & electric, etc.)	Electric 3kVcc; diesel	Electric 3kVcc; diesel	Diesel	Diesel	25 kVac / 50 Hz	25 kVac / 50 Hz	25 kVac / 50 Hz
<b>Railway Gradient:</b>							
Maximum gradient	25,75 ‰	23,70 ‰	19,13 ‰	14 ‰	17.8 ‰	20,7‰	24,12 ‰
<b>Rails:</b>							
Type of rail	S49, UIC60	S49	S49	54 / 65 / 49 / 40	S49	S49/UIC60	UIC60
Rail grade	R260; R350HT	R260; R350HT	R260	R260	R260	R260	R260
Standard length of rail	90 m; 120 m; welded	90 m; 120 m; welded	90 m; 120 m; welded	Welded rail	Welded rail	Welded rail	Welded rail

Rail Line identification /name	Divča – Koper	Pivka - Ilirska Bistrica	Ljubljana - Kamnik	Bartolomeu - Zarnesti	Kayaş - Sincan	Divriği - Malatya	Malatya – İskenderun
Weight	49 / 60 kg/m	49 kg/m	49 kg/m	54 / 65 / 49 / 40 kg/m	49 kg/m	49/60 kg/m	60 kg/m
Maximum axle load	D3 (22,5 t/axle; 7,2 t/m)	C2 (20 t/axle; 6,4 t/m)	C4 (20 t/axle; 8 t/m)	20 t/axle; 8 t/m	D4 (22.5 t/axle; 8 t/m)	20 t/axle	20 t/axle;
Most common failures	Contraction, direction, corrugation, wear	Constriction, direction, corrugation (few)	direction, constriction, wear (few)	Slips, cracks	Rail wear, sleepers crack	Slips, cracks,	Subsidence
Other characteristics and technologies	Elastic fastening, base plate, insulating pad (pandrol, SKL2)	Stiff fastening, base plate, insulating pad	Stiff fastening, base plate, insulating pad	-	-	-	-
<b>Sleepers:</b>							
Types of sleepers	Wooden	Wooden	Wooden	Concrete, wooden	Concrete	Concrete	Concrete
Sleeper density	a' = 60 cm; 1.667 slippers / km	a' = 62,5 cm; 1.600 slippers / km	62,5 cm; 1.600 slippers / km	1667 pieces / km	1612 pieces/km	1612 pieces/km	1612 pieces/km
<b>Ballast:</b>							
Type of ballast	Lime stone	Lime stone	Lime stone	Crushed stone (magmatic rocks)	Basalt, granite	Basalt	Basalt
<b>Subgrade and formation:</b>							



Rail Line identification /name	Divča – Koper	Pivka - Ilirska Bistrica	Ljubljana - Kamnik	Bartolomeu - Zarnesti	Kayaş - Sincan	Divriği - Malatya	Malatya – İskenderun
Characteristics description	Flysch; lime stone; without speciality;	Mostly flysch; without speciality;	Gravel with clay; without speciality;	Without substrate; it is directly on earth platform	Without substrate, It is directly on earth platform	Without substrate, It is directly on earth platform	Without substrate, It is directly on earth platform
<b>Curves:</b>							
Minimum radius	241 m	232 m	200 m	230 m	500 m	250 m	237 m
<b>Cant:</b>							
Maximum cant	Max. allowed: 160 mm; Max. on line: 140 mm	Max. allowed: 160mm; Max on line: 150mm;	Max. allowed: 160 mm; Max. on line: 90 mm	125 mm	120 mm	130 mm	130 mm
<b>Joints rail:</b>							
% of line	0%	0%	0%	10%	-	20%	-
Types of used joints	/	/	/	Metal Brackets	-	Metal Brackets	-
<b>Welded rail:</b>							
% of line	100%	100%	100%	90%	100%	80%	100%
Welding method / technology	AT welding	AT welding	AT welding	Electric arc with pressure and contact; AT welding;	Flash butt welding; Adding material (aluminothermic welding)	Flash butt welding; Adding material (aluminothermic welding)	Flash butt welding; Adding material (aluminothermic welding)

Rail Line identification /name	Divača – Koper	Pivka - Ilirska Bistrica	Ljubljana - Kamnik	Bartolomeu - Zarnesti	Kayaş - Sincan	Divriği - Malatya	Malatya – İskenderun
Length permitted for welding rail	6 m (min.) 120 m (max.)	6 m (min.) 120 m (max.)	6 m (min.) 120 m (max.)	250m ÷ 270m (max.)	180 m	180 m	180 m
<b>Signalling and interlocking:</b>							
System Types	Electronic / electro – signalling; APB	Electronic / electro – signalling; station dependence	Electronic / electro – signalling; station dependence	Electro - mechanical	Electromechanical	Electromechanical	Electromechanical
<b>Level Crossings (LC):</b>							
Class of level crossings (in terms of road traffic density)	Public road (1 LC) Forest road (2 LC)	Regional road (1 LC); Local road (4 LC); Public road (2 LC); City street (1 LC); Forest road (4 LC); Delivery path (1LC);	Regional road (2 LC); Local road (6 LC); Public road (10 LC); City street (9 LC); Delivery path (8 LC); Footpath (1 LC);	C Type – They only have RS (lights and acoustic); B Type - They have RS and half barrier; - IR Type - only road signs		B Type - They have RS and <b>full barrier</b> ; IR Type - only road signs;	B Type - They have RS and <b>full barrier</b> ; IR Type - only road signs;
Manual or automatically operated	/	Automatically operated	Automatically operated	Automatically operated	Automatically operated	Automatically operated	Automatically operated

Rail Line identification /name	Divača – Koper	Pivka - Ilirska Bistrica	Ljubljana - Kamnik	Bartolomeu - Zarnesti	Kayaş - Sincan	Divriği - Malatya	Malatya – İskenderun
Track structure at level crossings, if changes	/	/	/	No changes	No changes	No changes	No changes
Safety issues	St. Andrew's Cross (3 LC)	St. Andrew's Cross (6 LC); Automatic safety device and barrier (7 LC)	St. Andrew's Cross (16 LC); Automatic safety device and barrier (19 LC); Automatic device and lighting road signs (1 LC)	Automatic level crossings are fail-safe.	Automatic level crossings are fail-safe.	Automatic level crossings are fail-safe.	Automatic level crossings are fail-safe.
<b>Track Maintenance:</b>							
Type of maintenance	Manual, mechanized	Manual; mechanized	Manual; mechanized	Manual; mechanized	Manual; mechanized	Manual; mechanized	Manual; mechanized
Maintenance schedule	Based on inspection; Sunday / Monday 6 hours gap	Based on inspection	Based on inspection	Monthly maintenance	Visual check - monthly maintenance; Measured railcar – once at 6 months	Visual check - monthly maintenance; Measured railcar – once at 6 months	Visual check - monthly maintenance; Measured railcar – once at 6 months
<b>Railways Modernization Projects:</b>							
Description of new planned projects	Second track, blueprints prepared 50%. During regular maintenance,	/	/	Annual planning: mechanized tamping; switch replacement	BAŞKENT - RAIL PROJECT; on the tender phase	Annual planning: mechanized tamping; switch replacement	Annual planning: mechanized tamping; switch replacement

Rail Line identification /name	Divača – Koper	Pivka - Ilirska Bistrica	Ljubljana - Kamnik	Bartolomeu - Zarnesti	Kayaş - Sincan	Divriği - Malatya	Malatya – İskenderun
	works rails changed from 49E to 60E system (pandrol on wooden slippers).						

All these case studies have in common:

- Routes with distinctive features (context or purpose); there are specific characteristics to study.
- A good availability of technical, financial and operational data, related to the infrastructure and operations.

## 3.7 Slovenia – case studies

### 3.7.1 Rail line Divača - Koper:

#### **Line category:**

Freight dominated route

#### **Functionalities:**

The line is categorized as a Main Line related to national consideration, it is single track, electrified line with 3 kVcc and has almost only freight traffic trains. There are only few passenger trains and full of freight trains per day.

Length line by sections: Divača – Prešnica: 16.5 km; Prešnica – Koper: 31.5km.

It is in the category D3, the maximal permissible axle load is 22.5 tons with gauge dimension: 1435 mm and clearance gauge: UIC B 505, which is compatible with intermodal transport.

The Divača – Koper line has the characteristics of a mountain railway, with high slopes and small radii. The starting point of the line is in Divača at 431.1 m above sea level. The line reaches sea level at Koper Freight station. The highest altitude station of the line is the station Rodik, at 537.6 m. The maximal gradient is 25.8 ‰ over 300 m between Hrastovlje and Rižana, while the minimal radius of the curve is 250 m (in section Črnotiči – Hrastovlje).

#### **Performances:**

Average number of passenger trains per day is 11. Average number of freight trains per day is 79. Capacity of the line is 82 trains per day. Maximal speed is 90 km/h.

The maximal line speed is between 65 km/h and 75 km/h for freight trains and 90 km/h for passenger trains.

In year 2014 the following parameters were registered: 4 684 PT (passenger trains) – 0.1 MP (millions passengers) and 20 375 FT (freight trains) – 11.04 Mt (millions of tons).

#### **Economic aspects:**

There are only short (few hours) possessions for maintenance works. The main problem is wearing of rails, because of heavy trains and steep slopes (inclination). Maintenance is difficult also because of no accessibility by road and of course, before mentioned heavy traffic. During summer there are also considered fire precautions.

The Divača – Koper railway line is particularly important for international rail freight traffic, given the role of the Port of Koper in linking the Slovenian hinterland with the European economy.

Need to upgrade from single to double tracks line. Second track will be shorter and with less inclination.

#### **Other characteristics:**

Year of construction related to sections: Divača – Prešnica: 1876; Prešnica – Koper: 1967.

The railway line consists of two line sections. The line section Divača – Prešnica junction was constructed in 1876 in the scope of “Istrian state railways”, when the railway line Divača – Pula was

being constructed. The line section from Prešnica junction to Koper was constructed in 1967. Passenger traffic started in 1972 and, in 1979, a new passenger station in Koper was built.

The line was electrified in 1976. The catenary is supplied from electrical substations (ESS) at Divača, Črnotiče and Rižana. In the course of modernization, two electrical substations were set up in Dekani and Hrpelje – Kozina.

Quality of the track is according to national regulations. There are several types of inspections to control the quality of the track from personal inspections, hand measurement, and land survey measurement, geometrical parameters measuring by train inspection, dynamic parameters measuring train inspection.

#### **Considerations for improvements:**

Being dominated freight line, will be explored the possibility to become a dedicated freight line. The main objective to become a dedicated freight line is increasing axle load capacity of 25 tons. For new lines, the design phase can establish superior technology and high level of quality for materials that will be used, so as to reach full capacity of 30 tons per axle. For existing conventional lines the objective of improving is to reach 25 tons per axle; this is the case of analysed line (see Chapter 2.10.3).

Actual maximal speed for **Divača-Koper**, freight transportation, is 75 km/h; with infrastructure modernization, the speed of 100 km/h isn't hard to reach.

Measures for infrastructure modernisation:

- Should be used heavier rail sections (e.g. 52 kg/m, 54 kg/m, 60 kg/m, etc.). Now are ongoing activities, during regular maintenance, of replacing rails from 49E to 60E (60 kg/m) with pandrol fastening system, but on wooden sleepers. This category of rail permits upgrade of the track to support axle load of 25 tons. IM's of this line have already started to introduce the UIC 60 type rail as modernization.
- For significant improvement, wooden sleepers should be replaced with pre-stressed concrete sleepers. Pre-stressed concrete sleepers (PSC) and elastic fastenings will provide resilience of the track, ensure the smooth movement of trains at high speeds and have a long life of 50 to 60 years and very low maintenance (see Chapters 1.4.3; 2.8.2).
- Inspection of track and maintenance activities should reach a high level of precision and quality; should be considered mechanized maintenance as modernization, in order to ensure better track geometry, facilitate increasing speeds and smooth travel.
- Adopting long welded rails or even continuously welded rails on the entire route, will ensure noiseless travel and minimum maintenance (see Chapter 1.9.5).
- Upgrading ballast from lime stone to a hard stone composition, like granite, quartzite, and other hard rocks, will decrease time and costs of maintenance and also better resist movement for higher loads (see Chapter 1.3.1).
- A significant improvement will be achieved by replacing the rails at the quality of R260 to R350HT and beyond. As shown in the comparative table, IM's of the line Divača-Koper, began the process of improving the rail grade. Immediate results will be seen by increasing load

axle capacity and reducing maintenance costs, especially for vulnerable sections such as curves and switch and crossings points (see Chapter 2.4.3).

The most important modernization can be achieved by converting power supply system from the used 3kVcc to the European standard: 25kVac/ 50Hz. The benefits from technical point of view will be posted in reducing component wearing and increasing traction power. Also, economic benefits will be defined as lower cost of maintenance and operational activities. Economic profitability will increase because of interoperability at European level; the line will be compatible with railway networks in Europe. The journey times for passengers and freight transportation will decrease and the line will become more attractive to European rolling stock operators.

**Divača-Koper** line has gradient (26 ‰) which represents almost mountain gradient category (30 ‰). For this reason, the rails will support accelerated wear, but it also for wheels of rolling stock. There are two possible solutions: the train should use increased traction power through using EMU (Electrical Multiple Unit) or DMU (Diesel Multiple Unit) rolling stocks or, the second solution, in order to remain within the ruling gradient and the train to have enough traction power, the length of the railway line should be increased artificially for achieving a gradient to be in permissible limits. The alignment could be zigzagged or spiral, to gain heights easily (see Chapter 2.2.2).

### **3.7.2 Rail line Pivka - Ilirska Bistrica**

#### **Line category:**

Low density rural / secondary line

#### **Functionalities:**

This particular electrified single track line with 3 kVdc, has mixed traffic, some passenger trains and some freight trains. There are only few passenger and freight trains per day.

Length of railway line: 24.5 km.

Gauge dimension and clearance gauge: 1435 mm; UIC B 505.

Contrary to its high economic importance, the axle load category of line is rather limited (category C, i.e. 20 t / axle).

#### **Performances:**

Average number of passenger trains per day is 14. Average number of freight trains per day is 6.

Capacity of the line is 63 trains per day.

Maximal speed is 75 km/h.

In year 2014 the following parameters were registered: 4 141 PT (passenger trains) – 0.02 MP (millions passengers) and 1 451 FT (freight trains) – 0.57 Mt (millions of tons).

#### **Economic aspects:**

The railway line Pivka - Ilirska Bistrica - Šapjane (HŽ – Croatian Railways) is extremely important for the port of Rijeka. It also serves an alternative route that of Rijeka-Zagreb. With the liberalization of the rail transport market in Croatia, this railway line will also become a major force, because it provides the shortest route from the port of Rijeka to Central Europe.

**Other characteristics:**

The border station for traffic exchange is Šapjane in Croatia (HŽ), which is fitted with two systems of electrification, namely 3 kVdc (SŽ) and 25 kVac/ 50 Hz (HŽ).

Quality of the track is according to national regulations. There are several types of inspections to control the quality of the track from personal inspections, hand measurement, land survey measurement, geometrical parameters measuring train inspection, dynamic parameters measuring train inspection (not on this particular line).

**Considerations for improvements:**

**Pivka - Ilirska Bistrica** is low-density line. Increasing traffic density is mainly dependent on external factors but if it will be possible to decrease the maintenance cost and the line section will become more economic.

As presented considerations for improvement and modernization for line **Divača-Koper**, these could be synthesized for **Pivka - Ilirska Bistrica**:

- Upgrading ballast from lime stone to a hard stone composition.
- The use heavier rail sections (e.g. 60 kg/m).
- Replacing wooden sleepers with pre-stressed concrete sleepers.
- Adopting mechanized maintenance to ensure better track geometry and no human errors.
- Adopting rail grade quality from R260 to R350HT and beyond. IM's of the line Pivka – Ilirska Bistrica, began the process of improving the rail grade.
- Converting power supply system from 3kVcc to the European standard: 25kVac/ 50Hz.
- Reducing high gradient for gaining traction power and lowering energy consumption.

### 3.7.3 Rail line Ljubljana - Kamnik

**Line category:**

Busy passenger

**Functionalities:**

The line is categorized as a Regional Line, non-electrified single track line has mixed traffic, mostly passenger trains and some freight trains. There are many passenger trains per day, much more than freight trains. Stations are close due to serve passenger needs.

Length of railway line: 23.6 km.

Gauge dimension and clearance gauge: 1435 mm; UIC B 505.

The Ljubljana Šiška - Kamnik Graben line exhibits 5 stations and 10 stops.

**Performances:**

Average number of passenger trains per day is 44. Average number of freight trains per day is 4. Capacity of the line is 67 trains per day.

Maximal speed is 100 km/h.



In year 2014 the following parameters were registered: 10 276 PT (passenger trains) – 0.4 MP (millions passengers) and 506 FT (freight trains) – 0.08 Mt (millions of tons).

**Economic aspects:**

The line is one of the most important routes supporting suburban commuter traffic. SŽ is constantly endeavouring to provide passengers with high quality of service, both by offering modern and flexible train schedules, as well as with a single ticket for suburban transport of passengers.

Following the evolution of transport in particular suburban areas, Kamnik railway line belongs to the main regional lines of SŽ.

In addition to numerous factories in the area, an important gunpowder factory was established on the river Kamniška Bistrica, which resulted in the accelerated construction of the Kamnik railway line. At present, the Kamnik railway line is important for both freight and passenger transport.

**Other characteristics:**

The 23.6 km long railway line between Ljubljana and Kamnik was opened to traffic in early 1891.

Quality of the track is according to national regulations. There are several types of inspections to control the quality of the track from personal inspections, hand measurement, land survey measurement, geometrical parameters by measuring train inspection, dynamic parameters measuring train inspection (not on this particular line).

**Considerations for improvements:**

For a railway line used mainly for passenger transport, the biggest improvement is turning it into an electrified line. This will allow a substantial increase travel speed by increasing traction power but also a shortening starting and acceleration in stations; these times are important because railway lines, used specially by traffic suburban commuters, have high density of stations. Standard power supply is recommended to be 25 kVac/ 50Hz as interoperable with main lines across European networks and especially with neighbours that border.

Considerations for improvement and modernization could be synthesized also for **Ljubljana - Kamnik**:

- Upgrading ballast from lime stone to a hard stone composition.
- The use heavier rail sections (e.g. 60 kg/m).
- Replacing wooden sleepers with concrete sleepers or even pre-stressed concrete sleepers.
- Adopting mechanized maintenance to ensure better track geometry and no human errors.
- Adopting rail grade quality from R260 to R350HT and beyond.

## **3.8 Romania – case study**

### **3.8.1 Rail line Bartolomeu - Zarnesti**

**Line category:**

Low density rural / secondary line

**Functionalities:**

Rail line Bartolomeu – Zărnești is simple track, non-electrified, having a length of 23.9 km. Line category is mixed - passenger traffic (mainly) and freight traffic.

Gauge dimension and clearance gauge: 1435 mm; UIC B 505.

**Performances:**

Average number of passenger trains per day is 28. Average number of freight trains per month is 148. Capacity of the line is 50 trains per day. Maximal speed is 80 km/h.

At level of year 2014 was registered next parameters: 10 220 PT (passenger trains) – 0.6 MP (millions passengers) and 192 FT (freight trains) – 0.37 Mt (millions of tons)

**Economic aspects:**

Bartolomeu - Zărnești railway, with a length of 23.9 Km, was inaugurated on June 6th, 1891. Opened at the beginning to freight transportation, it became important also for passenger transport because of the numerous factories in the area, and also from a touristic point of view (Rasnov and Bran castles).

The main expenses: maintenance, operation, rent.

The main benefits: TUI (the infrastructure fee), access contracts for industrial lines, rental spaces and land.

**Other characteristics:**

There are only short time (few hours) for maintenance works. The main problem is rail traffic density, which is why works that take longer, are made night. During winter can be problems with snow.

Descriptive data is easily available for this case study, as this line section was also examined under the SATLOC project.

Quality of the track is according to national regulations. There are several types of inspections to control the quality of the track from personal inspections.

In 2005, the railway line was leased to RC-CF TRANS SRL Brasov who saw in this line a great opportunity for development, both in terms of freight and passenger transport. Between 2012 and 2014, the line was included in SATLOC project, with the main objective to prove, by tests and live demonstration, that GNSS is compliant with rail requirements for train control functions on low-density lines. SATLOC remains however compatible with ETCS developments.

**Considerations for improvements:**

**Bartolomeu – Zărnești** is a low-density line. Increasing traffic density is mainly dependent on external factors but if it will be possible to decrease the maintenance cost, the line section will become more economic.

Improvements solutions:

- The use heavier rail sections (e.g. 54kg/m; 60 kg/m, etc.); now there are mixed sections with various rails types.

- Replacing wooden sleepers with concrete sleepers or even pre-stressed concrete sleepers, on entire route;
- Adopting mechanized maintenance to ensure better track geometry and no human errors.
- Adopting rail grade quality from R260 to R350HT and beyond.
- Replacing the remaining 10% of jointed rail with welded rail, so the maintenance activities will decrease.

### 3.9 Turkey – case studies

#### 3.9.1 Kayaş - Sincan

**Line category:**

Busy passenger

**Functionalities:**

This line is an electrified line with automatic block system. The length of the line is 37 km. The gauge of the line is standard (clearance gauge UIC B 505, track gauge 1435mm). The traction system is 25kVac/ 50 Hz.

Number of tracks between sections:

- Kayaş-Ankara: 3 lines
- Ankara-Marşandiz: 4 lines
- Marşandiz-Sincan: 3 lines

The maximum gradient on the line is 17.8 ‰. A block system with 3-aspect signals is used; block section length is the same for all lines, namely 700 meters.

**Performances:**

Average number of passenger trains per day is 28. Average number of freight trains per month is 148. Capacity of the line is 50 trains per day. Maximal speed is 80 km/h.

This line manages with 2,809,040 passenger train.km/year and 1,161,430 freight train.km/year; number of freight trains per year: 7 174 FT. Gross-Tonnage.km are 16,222 for Ankara-Marşandiz, 30,968 for Marşandiz-Sincan and 22,014 for Ankara-Kayaş. The Sincan-Kayaş railway line comes second for passenger transportation amongst TCDD lines.

The maximum speed of the line is uniformly set at 120 km/h.

At level of year 2014 was registered next parameters: 196 599 PT (passenger trains) – 16 MP (millions passengers) and 7174 FT (freight trains).

**Economic aspects:**

For this line, related to 2014, were identified and separated two revenue categories:

- Revenue from passenger transportation component: 884381 €/year. On this line are used the following passenger trains: DOĞU EKSPRESİ; GÜNEY – VANGÖLÜ; İZMİR-MAVİ; POLATLI EKSPRESİ; ÇUKUROVA; KIRIKKALE EKSPRESİ; BANLİYÖ.
- Revenue from freight transportation component, by sections of the line:

- Ankara-Marşandiz: 341650 €/year;
- Marşandiz-Sincan: 652215 €/year ;
- Ankara-Kayaş: 463635 €/year

#### **Considerations for improvements:**

For a railway line used mainly for passenger transport, the concerning for improvements are the increasing speed of transportation and shortening starting and acceleration time in stations; these times are important because railway lines, used specially by traffic suburban commuters, have high density of stations.

Improvement for the line Sincan-Kayaş could be synthesized for:

- Adopting mechanized maintenance to ensure better track geometry and no human errors.
- Adopting rail grade quality from R260 to R350HT and beyond.
- The use heavier rail sections (e.g. 60 kg/m).

### **3.9.2 Divriği - Malatya**

#### **Line category:**

Low density rural / secondary line

#### **Functionalities:**

This line is an electrified and signalled single-track line, with length of 207 km.

The gauge of the line is standard (clearance gauge UIC B 505, track gauge 1435mm). The traction system is 25kVac/ 50 Hz.

The line is in axle load category of D4 (22.5 t/axle, 8.0 t/m) and the maximum speed of the line is 120 km/h.

The maximum gradient on the line is 24.12‰.

A block system with 3-aspect signals is used; block section length is the same for all lines: 700 meters.

#### **Performances:**

At level of year 2014 was registered next parameters: 5 691 PT (passenger trains) – 0.49 MP (millions passengers) and 22 597 FT (freight trains) – 0.37 Mt (millions of tons).

The overall passenger train traffic represents 915,420 ton.km per year, and 5,797,660 ton.km per year for freight. The gross freight ton.km between Divriği and Çetinkaya amount to 407,683; between Çetinkaya and Hekimhan, to 438 379, and between Hekimhan and Malatya to 561,806.

At level of year 2014 was registered next parameters: 691 PT (passenger trains) – 0.49 MP (millions passengers) and 22 597 FT (freight trains).

#### **Economic aspects:**

For this line, related to 2014, were identified and separated two revenue categories:

- Revenue from passenger transportation component: 359064 €/year. On this line are used the following passenger trains: DOĞU EKSPRESİ; GÜNEY-VANGÖLÜ; 4EYLÜL.

- Revenue from freight transportation component, by sections of the line:
  - Divriği-Çetinkaya: 8586191 €/year;
  - Çetinkaya-Hekimhan: 9232678 €/year
  - Hekimhan-Malatya: 11832168 €/year

The main expenses for this line is considered to be the maintenance operations and the rent.

Divriği-Malatya line section is low-density line. Increasing traffic density is mainly dependent on external factors but if it will be possible to decrease the maintenance cost, the line section will become more economic.

**Other characteristics:**

The main problematic of the line section is winter condition is very hard. It snows more than other sections and due to snowing and icing, some problems on track and S&C occurs.

**Considerations for improvements:**

As the other lines from this category, the improvements are dictated by economic factor that should guarantee returning of investment by future railway operating. Increasing traffic density is mainly dependent on external factors but if it will be possible to decrease the maintenance cost, the railway line will become more economic.

Improvements solutions:

- The use heavier rail sections (e.g. 54kg/m; 60 kg/m, etc.); now there are mixed sections with various rails types.
- Adopting mechanized maintenance to ensure better track geometry and no human errors.
- Adopting rail grade quality from R260 to R350HT and beyond.
- Replacing the remaining 20% of jointed rail with welded rail, so the maintenance activities will decrease.

### 3.9.3 Malatya - İskenderun

**Line category:**

Freight dominated route

**Functionalities:**

This line is an electrified and signalled single-track line, with length of 374 km.

The gauge of the line is standard (clearance gauge UIC B 505, track gauge 1435mm). The traction system is 25kV 50 Hz.

The line is in axle load category of D4 (22.5 t/axle, 8.0 t/m) and the maximum speed of the line is 120 km/h. The maximum gradient on the line is 21‰.

A block system with 3-aspect signals is used; block section length is the same for all lines: 700 meters.

**Performances:**

At level of year 2014 was registered next parameters: 3 593 PT (passenger trains) – 0.58 MP (millions passengers) and 38 088 FT (freight trains).

The number of Passenger Train-km / year is 591,300 and, the number of Freight Train - Km / Year is 16,260,750. The Gross-Tonnage-Km between Malatya and Narlı is 1,522,527, between Narlı and Fevzipaşa is 675,174, between Fevzipaşa and Toprakkale is 613,954 and between Toprakkale and Iskenderun is 425,459.

The overall passenger train traffic represents 915,420 ton.km per year, and 5,797,660 ton.km per year for freight. The gross freight ton.km between Divriği and Çetinkaya amount to 407,683; between Çetinkaya and Hekimhan, to 438 379, and between Hekimhan and Malatya to 561,806.

At level of year 2014 was registered next parameters: 3 593 PT (passenger trains) – 0.58 MP (millions passengers) and 38 088 FT (freight trains).

#### **Economic aspects:**

This line is of significant importance, due to the connection with Iskenderun Port and Iskenderun Iron and Steel Plant. As per 2011 statistics, the number of loaded goods is 489,000 t and unloaded goods, 1,044,000 t at the port. The revenue of the Iskenderun Port is over 12.5 million TL annually. Line capacity enhancement is expected to increase the revenue of the port by increasing the capacity of usage of the hinterland, by means of decreasing the downtime related to maintenance. The connection to the iron and steel plant is also of significant importance for freight transportation. In particular, iron ore is mined from Divriği and transported to Iskenderun by rail.

For this line, related to 2014, were identified and separated two revenue categories:

- Revenue from passenger transportation component: 782208 €/year. On this line are used the following passenger trains: DOĞU EKSPRESİ; FIRAT EKSPRESİ.
- Revenue from freight transportation component, by sections of the line:
  - Malatya-Narlı: 32065864 €/year;
  - Toprakkale-İskenderun: 14219806 €/year;
  - Toprakkale-Fevzipaşa: 12930454 €/year;
  - Fevzipaşa-Narlı: 8960571 €/year;

#### **Considerations for improvements:**

This line is dominated by the freight transportation; will be analysed the possibility to become a dedicated freight line.

The main objective is increasing axle load capacity by 25 tons; now, they have 20 t/axle load which means the inferior capacity for a freight dedicated route.

Measures for infrastructure modernisation:

- Inspection of track and maintenance activities should reach a high level of precision and quality; should be considered mechanized maintenance as modernization, in order to ensure better track geometry, facilitate increasing speeds and smooth travel.
- Adopting long welded rails or even continuously welded rails on the entire route, will ensure noiseless travel and minimum maintenance. (see Chapter 1.9.5).

- Upgrading ballast from lime stone to a hard stone composition, like granite, quartzite, and other hard rocks, will decrease time and costs of maintenance and also better resist movement for higher loads. (see Chapter 1.3.1).
- A significant improvement will be achieved by replacing the rails at the quality of R260 to R350HT and beyond. (see Chapter 2.4.3).

Malatya – İskenderun line has gradient (24, 12 ‰) which represents almost mountain gradient category (30 ‰). For this reason, the rails will support accelerated wear, because of friction between wheels and rails. There are two possible solutions: the train should use increased traction power through using EMU (Electrical Multiple Unit) rolling stocks or, the second solution, in order to remain within the ruling gradient and the train to have enough traction power, that sections of line, with highest gradient, should be increased artificially for achieving a gradient value to be in the permissible limits. The alignment could be zigzagged or spiral, to gain heights easily. (see Chapter 2.2.2).

## 4. Conclusions

---

Growth in demand for rail transportation across Europe is predicted to continue. Much of this growth will have to be accommodated on existing lines that contain old infrastructure. This demand will increase both the rate of deterioration of elderly assets and the need for shorter line closures for maintenance or renewal interventions. The impact of these interventions must be minimized and will also need to take into account the need for lower economic and environmental impacts. New interventions will need to be developed along with additional tools to inform decision makers about the economic and environmental consequences of different intervention options being considered.

Subgrade (formation) is the natural soil that has to be compacted and prepared at highest density, to receive the ballast, sleepers and rails. The track has to take in consideration into design that the stresses transmitted to the formation have not exceed the permissible limits. The subgrade may fail in different modes, and corrective measures should be taken in time to protect the track. The subgrade should be given special attention for lines of a freight dominated route category. Compacting soil should provide high density, necessary for supporting large cargo loads.

The ballast is a layer of granular material provided below and around the sleepers. Ballast has to distribute the loading from the sleepers, over a large surface of the formation. The ballast gets crushed because of the dynamic action of the wheel load and, therefore, requires regular maintenance.

Sleepers for rails act as support and have to transfer the load of moving trains to the ballast and formation. Wooden sleepers are most used but the negative characteristics as durability and life cycle have led to the development of metal and concrete sleepers. Concrete sleepers have high strength and a long life, and are most suitable for modern tracks. An improved variant is pre-stressed concrete sleepers and these are being extensively used on all important routes. For all the types of track focused in the project: busy passenger, low density rural/secondary line and freight dominated route, upgrading to concrete sleepers, better to pre-stressed concrete sleeper type, is one of the first recommendation for improvements.

A rail section may develop different types of defects during its service life. Various types of rail sections and their specifications have been discussed. Defects in a rail should be attended immediately, otherwise it will lead to the failure of the rail; types of defects in a rail and the remedial measures to be adopted have been highlighted.

Fish-plated joints for rail are used to join rails in series but there are the most vulnerable components of a track, as accelerated wear points. Welded rail joints are the most suitable as they satisfy almost all the requirements of an ideal rail joint. There are several methods of welding rails but the flash butt and thermite welding methods are normally preferred.

LWR (long welded rail) are rails that are welded in multiple panels. The central portion of an LWR remains clamped and does not undergo any change in length. Only the end portions of the LWR rails are affected by thermal expansion. Continuous welded rails (CWRs) are rails that are welded in



length greater than 1 km. LWRs and CWRs are part of modern high-speed tracks and require very little maintenance as compared to fish-plated tracks. For this reason, it is recommended for all types of track; even for low density rural/secondary line, replacing fish-plated joints with welding rails.

A turnout is a combination of lead rails and switch and crossings and are provided when two tracks are to be connected or when a branch line is to be introduced; it is possible to have various types of track junctions with different combinations of switches and crossings.

The new construction requires extensive planning and investment; preliminary investigations are carried out to determine the feasibility of the new project. Various kinds of surveys are conducted to these purposes; it is extremely important to conduct survey work as precisely as possible because the money spent on surveys is non-recoverable.

The alignment of a railway line is extremely important as subsequent costs of construction and operation depend heavily on it. The basic requirements and factors affecting alignment have been discussed in chapter related to technologies for completely new installations, or situations where significant rebuilding railway lines will be achieved. There are various types of engineering surveys required to mark the alignment of a railway line.

Special attention should be given for lines with high gradients. Solutions adopted for mountain alignment could be taken in consideration. To remain within the ruling gradient and the train to have enough traction power, the line should be lengthened, almost zigzagged, for achieving a gradient in permissible limits. This improvement is most useful for the freight dominated routes, where the friction force between wheels and rails is smaller than for plain lines and the locomotives have to provide more traction power for the same loaded goods.

The multiple gauge system has caused many problems and caused serious bottlenecks in the operation of the railways. The one gauge system will be highly beneficial to rail users, the railway administration, and the population.

An important aspect in the safety and maintenance of railways is the degradation of rail. Therefore, for a cost effective railway, guidelines for rail grade selection are presented with help from the research within the InnoTrack project. In modern and high performance railways it is recommend heat treated rail, at least R350HT at key locations to combat RCF. However, for cost efficiency on lower density railways the particular rail grade should be selected based on the traffic types and the track design and conditions.

Upgrading quality of rails grade represents an improvement for any category of railway line: for freight dedicated route but also for passenger capacity constrained line. For underutilised or rural secondary lines, changing rails with more resistant version means, first of all, reducing maintenance costs; but initial cost should be covered by the future revenue from line exploitation. For decision of new investments for this type of line, the economic factor will be decisive.

Switches represent a key asset of the railway infrastructure, which must be replaced with higher frequency than plain track given that they have to support higher stress. There is a wide range of methods being used to replace switches and crossings (S&C), with different results and installation qualities. Mainly used replacing procedure across Europe is: Pre-assembled in the vicinity of the

works. Modular switch (just in time) is the second procedure used and has growth potential as being less duration to work.

In the last part, are presented descriptions of used technologies and practices from partner's countries, with their particularities.

In the previous task (T1.1) is chosen a list with the seven lines to be analysed as cases study; for these lines had collected data and presented in a comparative table, with components and technologies used. Also, it has presented a detailed description with functionalities, performance and economic aspects for the case study lines.

Classification of railway lines in the three study cases is difficult because these lines were not originally built for the NeTIRail classifications of freight dominated, capacity constrained or low utilisation. However, over time these lines have come to fall into these categories due to changing demographics and transport needs.

Also, framing a railway line in one of the three categories, defined in project analysis, it is subjective; a line of high-density transport for one region could be a low-density transportation line for other infrastructure manager, in another geographic region. In this way, wear of rail infrastructure and maintenance activities costs are more pronounced, in the same period of time, for one situation than for the other, although both cases are qualified as high density transport.

The lines selected in T1.1 became case study subjects for almost all future tasks of the project. These lines are the following:

**Divača – Koper:** Freight dominated route (SZ – Slovenia);

**Pivka - Ilirska Bistrica:** Low density rural / secondary line (SZ – Slovenia);

**Ljubljana – Kamnik:** Busy passenger line (SZ – Slovenia).

**Bartholomew – Zarnesti:** Low density rural/ secondary line (RCCF - Romania).

**Kayaş – Sincan:** Busy passenger line (INTADER - Turkey).

**Divriği – Malatya:** Low density rural / secondary line (INTADER - Turkey).

**Malatya – İskenderun:** Freight dominated route (INTADER - Turkey).

All these case studies are routes with distinctive features (context or purpose) and for this reason there are specific characteristics to be studied; and they have good availability of technical, financial and operational data, related to the infrastructure and operations.

Guided by the key findings of this Deliverable, a number of broader recommendations for the NeTIRail-INFRA project, from wider research in this area, have been identified and are outlined below.

Main objectives when railways are modernized: allowing heavier trains to run safely and economically at faster speeds; improving productivity; providing better customer service to rail users.

Modern strategies for railways are focused on:

- Track and infrastructure modernization for high speed trains.
- Railway modernization adopting strategies focused for designing of dedicated freight routes which means for almost exclusively carrying freight traffic at higher speeds and increased axle loads.

For the situation of a busy passenger line infrastructure modernization is necessary to serve in good conditions the social demands. Meanwhile, expenses incurred by infrastructure improvements are economic feasible as this investment will be recovered from covering increased demand of passenger traffic; so in this situation a good return on investment is likely. The main directions of modernization are to increase the speed of trains in this category of line. In this reason next solutions for improvements should be taken in consideration:

- Electrification of railway line if are not existing; will increase traction power and capacity of transport; in the category of power supply systems, the variant with alternative current, according to European standard 25 kVac/ 50 Hz, is the optimum solution.
- Upgrading ballast to a hard stone composition.
- The use heavier rail sections for increasing transport capacity.
- Use concrete sleepers or even pre-stressed concrete sleepers on the entire route, including points and crossings; if it is economic feasible, the best solution is upgrading to slab track.
- Adopting mechanized maintenance to ensure better track geometry and no human errors.
- Adopting rail grade quality to R350HT and beyond. The improvement for the head hardened grade R350HT compared to standard grade R260 is about 3 times for wear and 2 times regarding RCF. The consequence related to a proper rail grade selection is that less maintenance would be required and the total lifetime of the rails would increase.
- Switch and crossings improvements – as the most vulnerable section from track - by using newest researching results, e.g. InnoTrack and MainLine projects.

Freight category dominated route also has the advantage that the investments could be recovered on the basis of covering the transport needs. Most important improvement for better utilisation of freight category dominated route is to increase the axle loads on the routes, with immediate result to increase railway capacity. The objectives could be summarised as to have axle loads of 30 tonnes for new lines because that could be designed according to highest technical requirements, and for the current lines to increase loading capacity up to 25 tonnes per axle, along with improvements to wagons.

Low density rural/ secondary lines represent a different situation. Increasing traffic density is mainly dependent on external factors. Modernisation of line involves costs that may not be recovered. In this way, increasing efficiency could be possible through decreasing the maintenance cost; with this strategy, the line section will become more economic. Any improvement proposed for the others categories will lead to decreasing maintenance expenses but the investment cost should be assessed to determine if it is economically acceptable, or the deployment of other low cost technologies should be substituted.

## 5. References

---

1. InnoTrack Deliverable D4.6.1; The influence of the working procedures on the formation and shape of the HAZ of flash butt and aluminothermic welds in rails . 2008.
2. InnoTrack Deliverable D4.6.6; Weld performance in track test – supervision of weld properties in terms of rail profile, rail straightness and neutral temperature (preliminary report). 2009.
3. InnoTrack Deliverable D4.6.3/D4.6.4; Analysis of equipment design and optimisation of parameters for gas pressure welding. 2008.
4. InnoTrack Deliverable D4.6.5; Gas pressure welding – Quality of test welds. 2009.
5. InnoTrack Deliverable D4.6.2; Report on the influence of the working procedures and post treatment on static and dynamic fatigue behaviour of aluminothermic welds. 2008.
6. InnoTrack Deliverable D4.2.1; The impact of vertical train-track interaction on rail and joint degradation. 2007.
7. InnoTrack Deliverable D4.2.4, Improved model for loading and subsequent deterioration due to squats and corrugation. 2009.
8. InnoTrack Deliverable D4.2.6, Recommendation of, and scientific basis for minimum action rules and maintenance limits. 2009.
9. Chandra, Satish and Agarwal, M.M. Railway Engineering (Second Edition). 2013.
10. Michas, G. Slab Track Systems for High-Speed Railways (Master Degree Project), Stockholm. 2012.
11. INTEROPERABILITY UNIT TRANS-EUROPEAN CONVENTIONAL RAIL SYSTEM SUBSYSTEM NFRASTRUCTURE IU-INF-090902-TSI Technical Specification of Interoperability. 2009.
12. Marich, S. and Mutton, P.J. Materials Developments in the Australian Railway Industry – Past, Present and Future, The Fourth Int. Heavy Haul Railway Conf. 1989.
13. Muster, H., Schmedders, H., Wick, K. and Pradier H. Rail rolling contact fatigue. The performance of naturally hard and head-hardened rails in track. 1996.
14. Heyder, R. and Girsch, G. Testing of HSH® rails in high-speed tracks to minimize rail damage. 2005.
15. InnoTrack Deliverable D452; Target Profiles.
16. Kassa, E. and Nielsen, J C O. Vehicle System Dynamics - Dynamic interaction between train and railway turnout – fullscale field test and validation of simulation models. 2008.
17. Project, MainLine. Deliverable 3.3 - Rail Switches and Crossings. Development of new technologies for replacement. 2014.
18. Muster, H., Schmedders, H., Wick, K. and Pradier H. Rail rolling contact fatigue. The performance of naturally hard and head-hardened rails in track. 1996.
19. Rail metallurgical developments to address the changing needs of the railways, World Congress of Rail research 2003. Boulanger, D. Edinburgh, Scotland : s.n., 2003.

20. Deroche, R.Y., Bettembourg, J.P., Prasil, B., Bertrand, J.P. and Juckum, C. Rolling Contact Fatigue Cracks on S.N.C.F Conventional Tracks, in Kalker et al., Rail Quality and Maintenance for Modern Railway Operation. 1993.

21. InnoTrack Deliverable D4.1.3 - Interim Guidelines on the selection of rail grades. 2006.

22. Perez, J. Optimisation of the dynamic gauge for railway switches, INNOTRACK Technical report. 2008.

23. Heyder, R. and Girsch, G. Testing of HSH® rails in high-speed tracks to minimise rail damage, Wear. 2005.